

# M7719 SERIES

## SINGLE-OUTPUT, 200W DC TO DC BASEPLATE COOLED POWER SUPPLY

The M7719 is a series of mechanically robust, base-plate cooled, high performance, power supplies, designed for Ground Mobile (MIL-STD-1275), Airborne (MIL-STD-704) and other Hi-Reliability applications where 28VDC has to be converted to a tightly regulated, filtered and protected DC output.



# M7719 Series– DC/DC Power Supply

**Standard Models List** (for other voltages – consult factory)

Part Number	Output Voltage	Max Output Current	Minimum Efficiency
M7719-101	12 V <sub>DC</sub>	10 A	87%
M7719-102	15 V <sub>DC</sub>	10 A	89%
M7719-103	24 V <sub>DC</sub>	8 A	90%
M7719-104	28 V <sub>DC</sub>	7.14 A	90%

- Additional standard configurations available. **Contact factory for more details.**

## M7719 Series– DC/DC Power Supply

### THE MAIN FEATURES OF THE M7719 ARE:

- DC/DC Single output power supply up to 200W
- 18 to 50VDC Standard Input version
- For standard Input version No damage due to abnormal transients IAW MIL-STD-1275 (100 V / 50 ms) and MIL-STD-704 (80 V / 0.1 s)
- For extended input version for 15V output - **Please contact factory for more details**
- High efficiency – up to 90% (depending on output voltage).
- Full galvanic isolation between Input, Chassis and Output
- External Inhibit (On/Off)
- Fixed switching freq. (290 kHz)
- EMI filters included
- Indefinite short circuit protection with auto-recovery
- Over-voltage protection
- Over temperature shutdown with auto-recovery
- High density
- Conduction cooled via the baseplate

## M7719 Series– DC/DC Power Supply

### SPECIFICATIONS:

<b>DC Input</b>	<b>Type</b>	28V <sub>DC</sub> per MIL-STD-704E
	<b>Voltage Range</b>	Steady state: 18 to 50 V <sub>DC</sub>
	<b>Transients</b>	No damage when expose to the following transients IAW MIL-STD-1275E: 12V, 1sec 16V,30sec 100V, 50msec No damage when expose to the following transients IAW MIL-STD-704A: 70V, 20 msec 80V, 0.5msec
	<b>Transients Optional</b>	<b>Optional:</b> Operation through 70V, 20 msec IAW MIL-STD-704A <b>Please contact factory for more details</b>
	<b>Isolation</b>	Input to Output: 200 VDC Input to Case: 200 VDC
	<b>Input Reverse Polarity</b>	Protection for unlimited time
	<b>Under-Voltage Lock-Out</b>	The unit shuts down below 16V ± 1V.
	<b>Over-Voltage Lock-Out</b>	The unit shuts down above 52V ± 1V.
<b>DC Output</b>	<b>Rating</b>	See table on page 7
	<b>Voltage Regulation</b>	Better than or equal to ±1% (low to high line voltage, no load to full load, –55 °C to +85 °C at baseplate).
	<b>Ripple</b>	150-300 mVp-p, typical (max. 1% of output voltage)
	<b>Isolation</b>	Output to Case: 100 VDC
	<b>Overvoltage Protection</b>	<b>Passive Over-Voltage Protection:</b> Zener diode installed on output terminals, selected at 120% ± 10% of nominal voltage.

## M7719 Series– DC/DC Power Supply

	<b><i>Efficiency</i></b>	Typical: 90%
	<b><i>Current Limit &amp; Overload</i></b>	Output voltage turns off and on periodically with low duty cycle (hiccup) to protect system conductors and converter from short circuit
	<b><i>Over Temp. Protection</i></b>	Output shuts down if base plate temperature exceeds $+105^{\circ}\text{C} \pm 5^{\circ}\text{C}$ . Automatic recovery when baseplate temperature returns to below $+95^{\circ}\text{C} \pm 5^{\circ}\text{C}$ .

## M7719 Series– DC/DC Power Supply

### Specifications (Cont.):

<b>Control &amp; Indication</b>	<i><b>INHIBIT Signal</b></i>	<p>The <b>INHIBIT</b> signal is used to turn the power supply ON and OFF. To turn the power supply OFF, apply a TTL “0” signal or SHORT to <b>VIN RTN</b>.</p> <p>To turn the power supply ON, apply a TTL “1” signal or leave this pin OPEN.</p> <p>If not used (always ON), leave this pin OPEN.</p> <p>This signal is referenced to <b>VIN RTN</b>.</p> <p><b>ENABLE Signal</b> - Optional - Please consult factory.</p> <p>To turn the power supply OFF, apply a TTL “1” signal or leave this pin OPEN.</p> <p>To turn the power supply ON, apply a TTL “0” signal or SHORT to <b>SIGNAL RTN</b>.</p>
<b>Environment Designed to meet MIL-STD-810F</b>	<i><b>Temperature</b></i>	<p>Methods 501.4 &amp; 502.4</p> <p>Operating: –55 °C to +85 °C (at baseplate)</p> <p>Storage: –55 °C to +125 °C (ambient)</p>
	<i><b>Humidity</b></i>	<p>Method 507.4</p> <p>Up to 95% RH</p>
	<i><b>Salt-fog</b></i>	<p>Method 509.4</p>
	<i><b>Altitude</b></i>	<p>Method 500.4</p> <p>Procedures I – Storage/Air transport: up to 70,000 ft. (non-operational)</p> <p>Procedure II – Operation/Air Carriage: up to 70,000 ft. (operational)</p>
	<i><b>Mechanical Shock</b></i>	<p>Method 516.5</p> <p>Procedure I</p> <p>20 g / 11 ms terminal peak half-sine shock pulse</p>
	<i><b>Vibration</b></i>	<p>Category 24: Minimum integrity, IAW figure E-3, 7.7 grams, 1 hour per axis.</p>
	<i><b>Fungus</b></i>	<p>Does not support fungus growth, in accordance with the guidelines of MIL-STD-454, Requirement 4-</p>
<b>EMI</b>	<i><b>MIL-STD-461F</b></i>	<p>Designed to meet* MIL-STD-461F CE101, CE102, CS101, CS114, CS115, CS116, RE101, RE102, RS101, RS103</p> <hr/> <p>*EMI Compliance achieved with 5μH LISN, shielded harness and static resistive load.</p>

## M7719 Series– DC/DC Power Supply

<b>Reliability</b>	150,000 hours, calculated per MIL-HDBK-217F Notice 2 at +85 °C baseplate, Ground Fix conditions.
<b>Cooling Requirements</b>	The M7719 is a baseplate cooled unit. The base of the M7719 should be thermally attached to a suitable heatsink that maintains it below +85 °C.
<b>Form factor</b>	1.83" wide, 0.72" high and 3.26" deep. For detailed dimensions and tolerances see Drawing: M7719001.
<b>Weight</b>	160g Typical
<b>Connectors</b>	<p><b>Connector: M24308/24-38F or eq.</b></p> <p><b>Mates with: M24308/2-2F or eq.</b></p>

*Test Results*

1. 28V Vout 200W plus

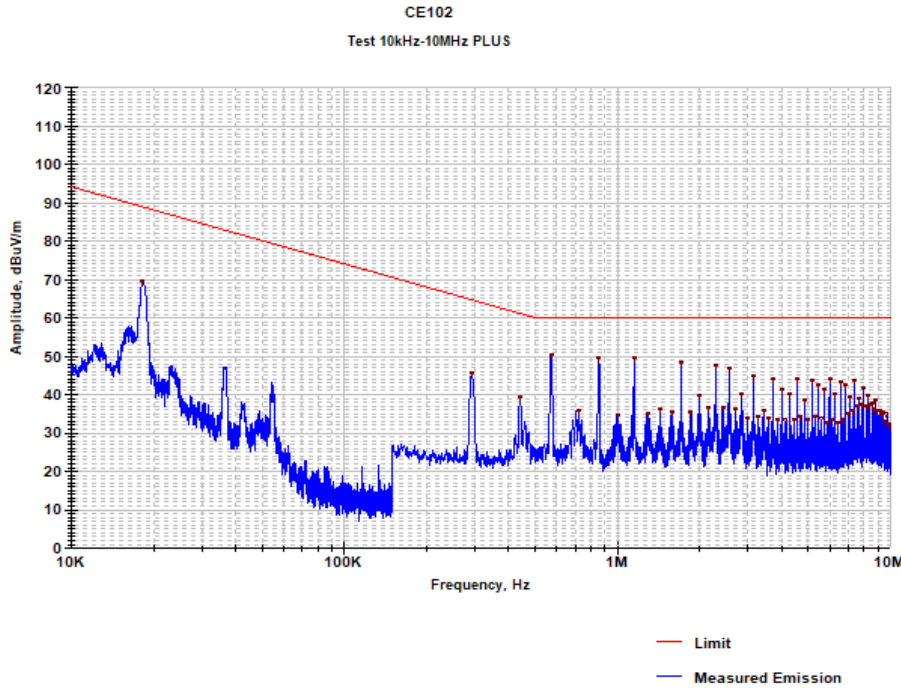

2. 28V Vout 200W minus

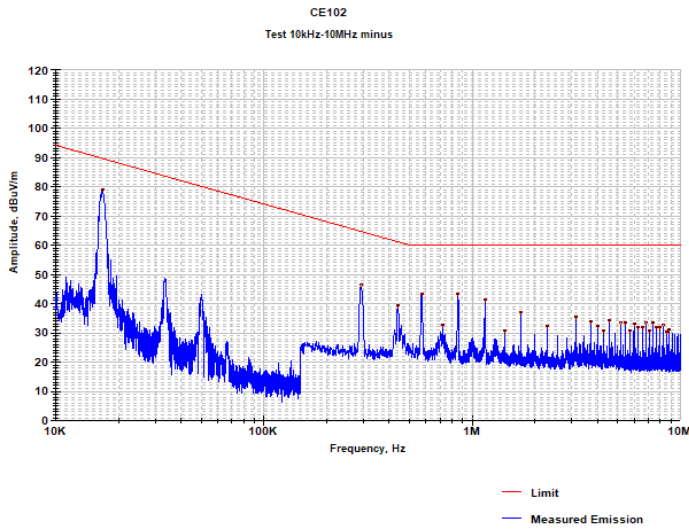

M7719 Series– DC/DC Power Supply

3. 28V Vout 200W minus (Vertical)

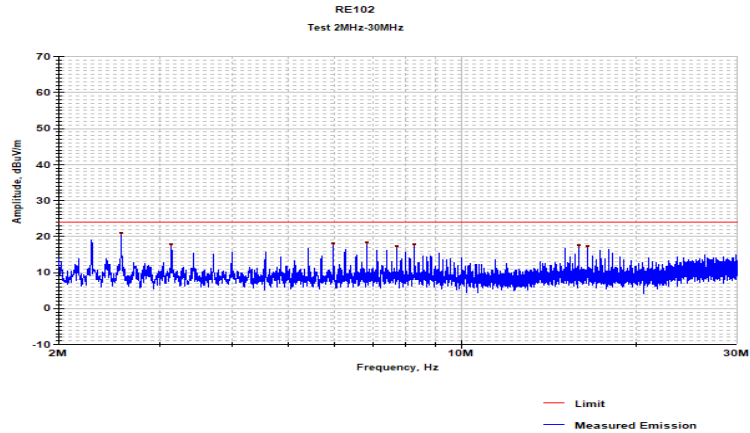

Frequency (MHz)	Measured Emission (dBuV/m)	Limit (dBuV/m)	Delta (dB)
2.566	20.8	24.0	-3.2
3.137	17.8	24.0	-6.2
5.987	17.9	24.0	-6.1
6.844	18.2	24.0	-5.8
7.701	17.2	24.0	-6.8
8.272	17.6	24.0	-6.4
15.966	17.4	24.0	-6.6
16.532	17.1	24.0	-6.9

**M7719 Series– DC/DC Power Supply**

a. Same measurement with 44 limit on display

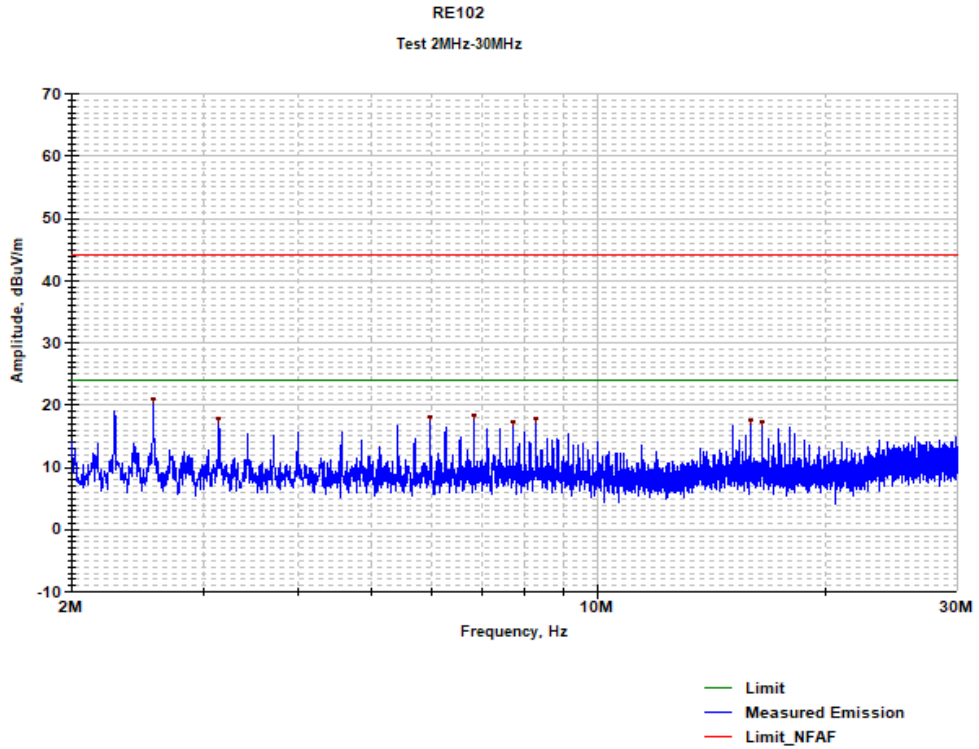

**M7719 Series– DC/DC Power Supply**

**4. Vertical, 200W:**

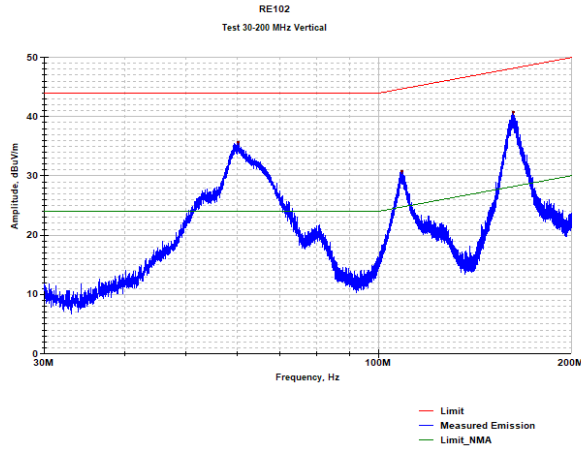

Frequency (MHz)	Measured Emission (dBuV/m)	Limit (dBuV/m)	Delta (dB)
60.209	35.60	44.00	-8.40
108.744	30.78	44.73	-13.95
162.039	40.64	48.18	-7.55

**M7719 Series– DC/DC Power Supply**

**5. Horizontal**

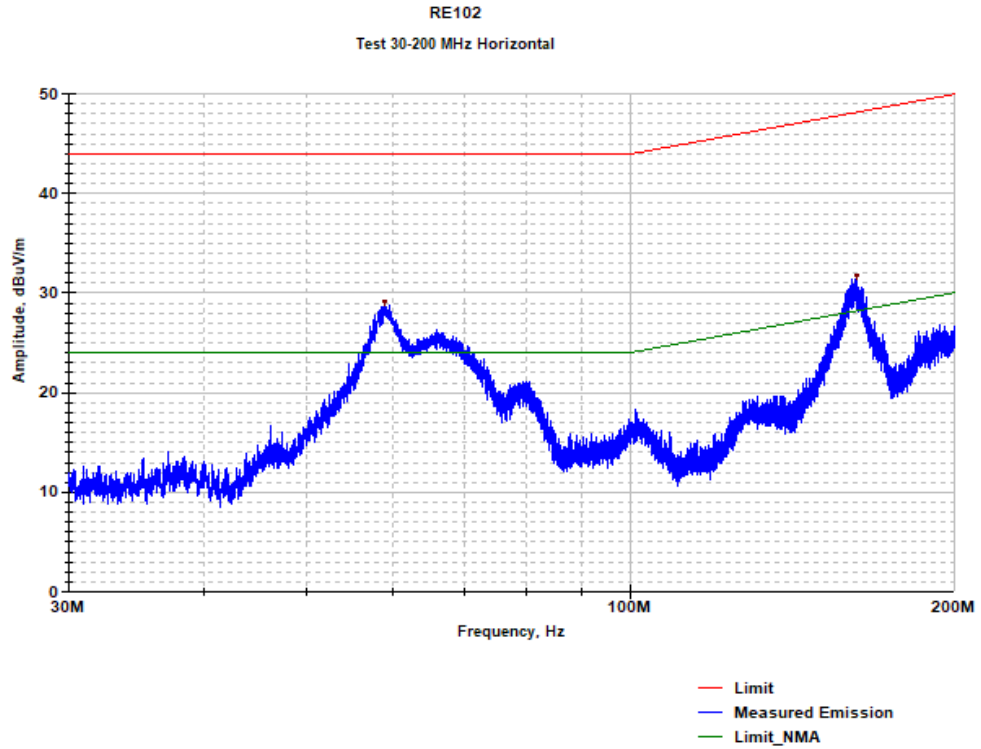

Frequency (MHz)	Measured Emission (dBuV/m)	Limit (dBuV/m)	Delta (dB)
59.019	29.1	44.0	-14.9
162.192	31.6	48.2	-16.6

**M7719 Series– DC/DC Power Supply**

**Vertical:**

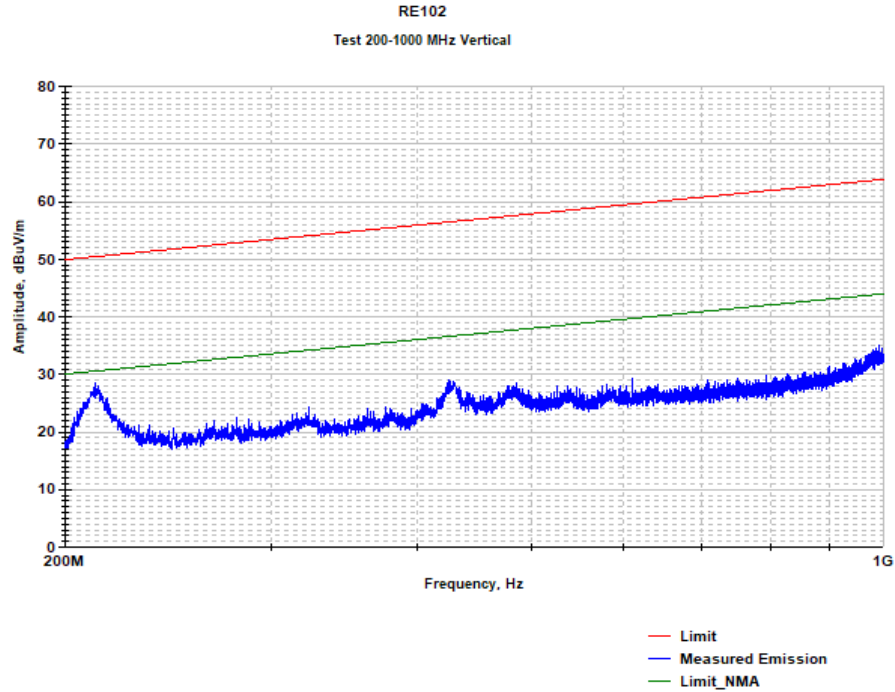

**6. Horizontal**

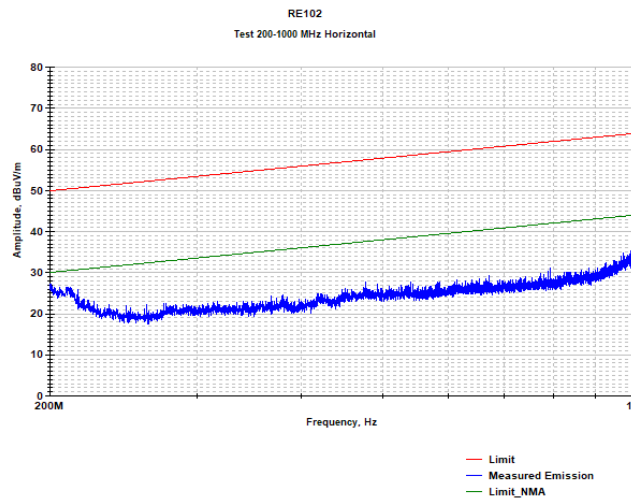

**M7719 Series– DC/DC Power Supply**

**7. Vertical:**

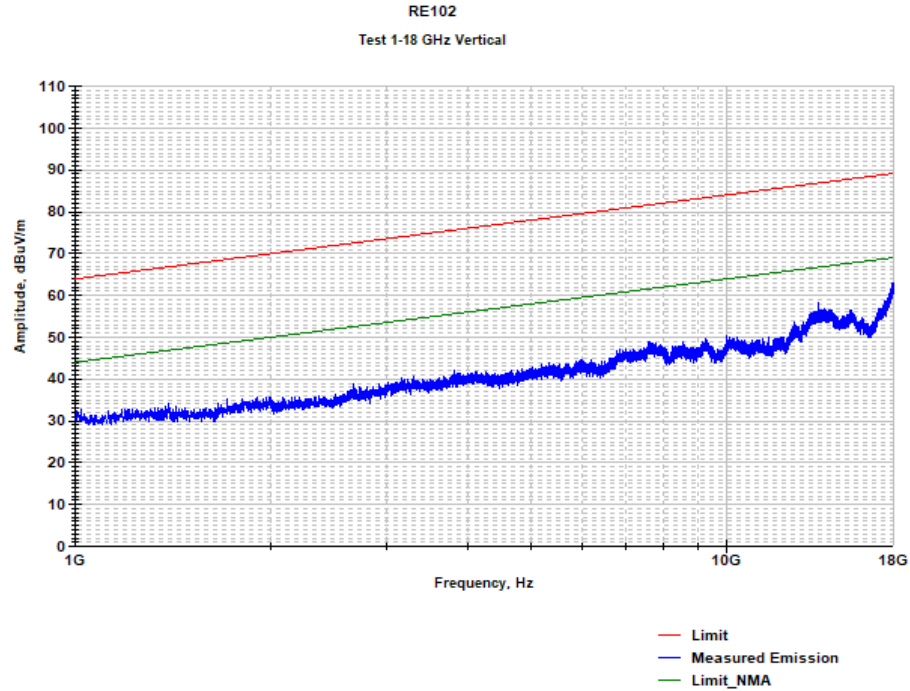

**8. Horizontal**

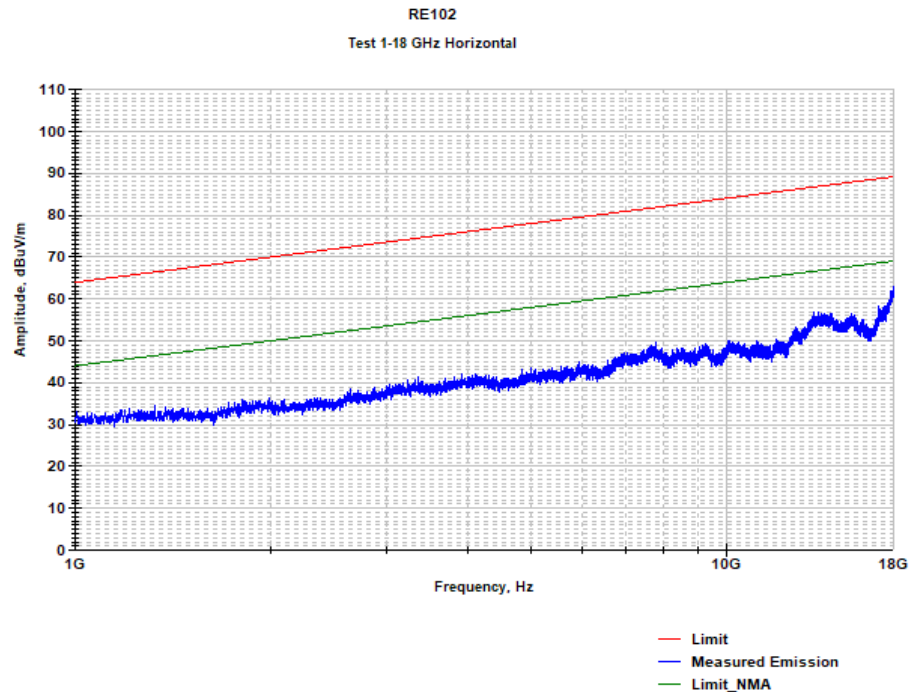

**M7719 Series– DC/DC Power Supply**

**TYPICAL CONNECTION DIAGRAM**

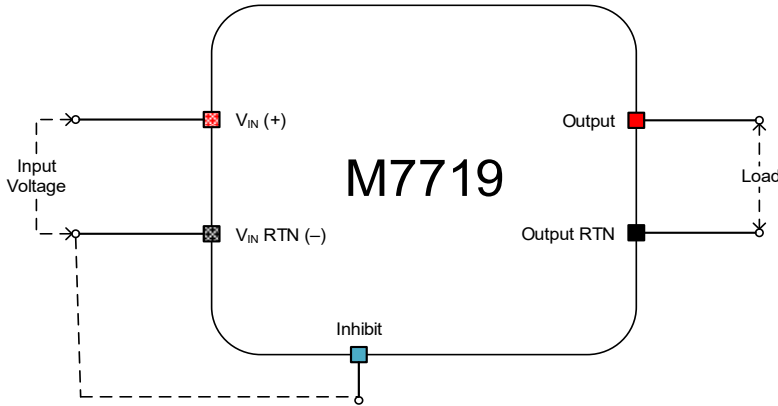

**Outputs Range**

Output #	Voltage Range	Current Range	Output Regulation	Power Range
1	12 to 28 V <sub>DC</sub>	10A max	±1%	200W max

## M7719 Series– DC/DC Power Supply

### PIN ASSIGNMENT:

**Connector:** M24308/24-38F or eq.

**Mates with:** M24308/2-2F or eq.

Pin No.	Function	
1	OUTPUT	+
2	OUTPUT	+
3	OUTPUT RTN	-
4	INPUT RTN	-
5	INPUT RTN	-
6	INPUT	+
7	INPUT	+
8	INHIBIT	

Pin No.	Function	
9	OUTPUT	+
10	OUTPUT RTN	-
11	OUTPUT RTN	-
12	INPUT RTN	-
13	INPUT RTN	-
14	INPUT	+
15	INPUT	+

Note: All pins with identical function/designation should be connected together for optimal performance.

**M7719 Series– DC/DC Power Supply**

**OUTLINE DRAWING:**

*For detailed dimensions and tolerances see Drawing: M7719001*

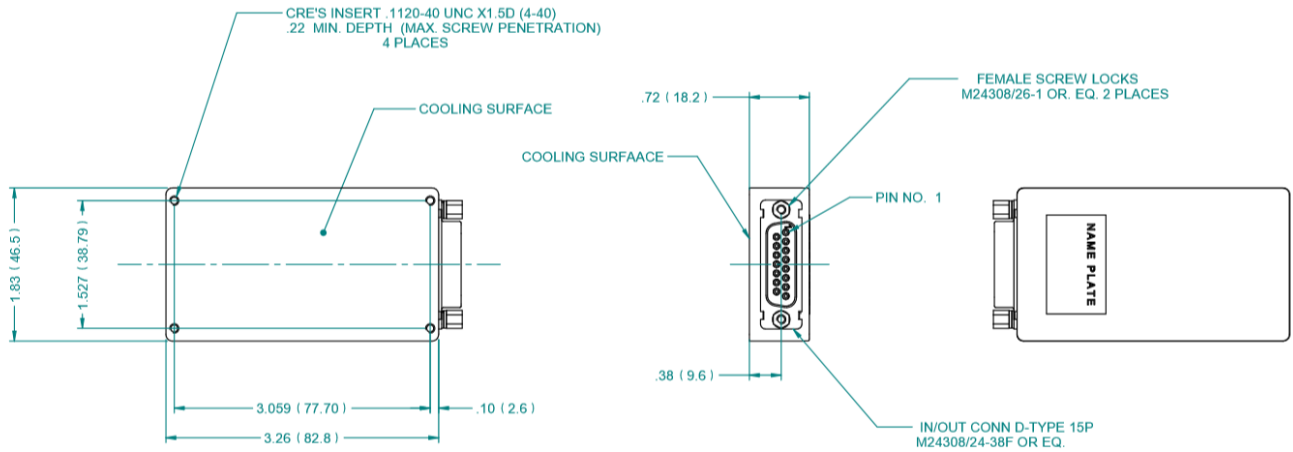

*Note: Specifications are subject to change without prior notice by the manufacturer.*