

# M7531 SERIES

## SINGLE-OUTPUT, 1000W DC TO DC BASEPLATE COOLED POWER SUPPLY

The M7531 is a series of mechanically robust, baseplate cooled, high performance, digital power supplies, designed for Airborne (MIL-STD-704), Ground Mobile (MIL-STD-1275) and other Hi-Reliability applications. The M7531 converts MIL-STD-704F and MIL-STD-1275E 28V power, to a well-regulated, filtered and protected DC Output.



## M7531 Series– DC/DC Power Supply

### Standard Models List (for other voltages – consult factory)

Part Number	Output		Power
	Voltage	Current	
M7531-101	12 V <sub>DC</sub>	50 A	600W
M7531-102	15 V <sub>DC</sub>	50 A	750W
M7531-103	24 V <sub>DC</sub>	42 A	1008W
M7531-104	28 V <sub>DC</sub>	36 A	1008W
M7531-105	48 V <sub>DC</sub>	20A	960W

- Additional standard configurations available. **Contact factory for more details.**
- All of our products can be configured to comply with EU REACH regulations. **Contact factory for more details.**
- Rides through transients IAW MIL-STD-1275E and MIL-STD-704F.

## M7531 Series– DC/DC Power Supply

### THE MAIN FEATURES OF THE M7531 ARE:

- DC/DC Single outputs power supply up to 1000W
- Standard Input version IAW MIL-STD-704F
- Standard Input version IAW MIL-STD-1275E
- Rides through transients IAW MIL-STD-1275E and MIL-STD-704F
- High efficiency – up to 88% (depending on output voltage).
- Full galvanic isolation between Input, Chassis and Outputs
- Digital control
- Optional: Parallel operation via output voltage droop. **Please consult factory.**
- Constant voltage and constant current operation
- External Inhibit (On/Off)
- Fixed switching freq. (250 kHz)
- EMI filters included
- Remote sense compensation
- Indefinite short circuit protection with auto-recovery
- Over-voltage protection
- Over temperature shutdown with auto-recovery
- High density
- Conduction cooled via the baseplate

## M7531 Series– DC/DC Power Supply

### SPECIFICATIONS:

<b>DC Input</b>	<b>Voltage Range</b>	28VDC input IAW MIL-STD-704F and MIL-STD-1275E
	<b>Transients</b>	Rides through transients IAW MIL-STD-1275E and MIL-STD-704F: 12V, 1sec 16V, 30sec 18V Continuous 50V Continuous 100V, 50msec
	<b>Isolation</b>	Input to Output: 200 VDC Input to Case: 200 VDC
	<b>Input Reverse Polarity</b>	Protection for unlimited time
	<b>Under-Voltage Lock-Out</b>	Unit shuts down when input voltage falls below 10.5VDC ±1VDC <b>Please consult factory for more details.</b>
	<b>Over-Voltage Lock-Out</b>	Unit shuts down when input voltage rises above 104V <sub>DC</sub> ±2V <sub>DC</sub> <b>Please consult factory for more details.</b>
	<b>DC Output</b>	<b>Rating</b>
<b>Voltage Regulation</b>		Better than or equal to ±1% (low to high line voltage, no load to full load, –55 °C to +85 °C at baseplate).
<b>Remote Sense</b>		<u>Description:</u> Used to achieve accurate voltage regulation at load terminals, to compensate for voltage drop across the leads connecting the converter to the load, 0.25 V ± 0.1 V <u>Use:</u> Connect SENSE line directly to the load's positive terminal, and SENSE RTN directly to the load's negative terminal. If not used, connect SENSE to OUTPUT and SENSE RTN to OUTPUT RTN. Do not leave open!
<b>Ripple</b>		Less than 50mV <sub>p-p</sub> , typical (max. 1%) without external capacitance. When connected to system capacitance ripple drops significantly.
<b>Isolation</b>		Output to Case: 100 VDC

## M7531 Series– DC/DC Power Supply

	<b>Overvoltage Protection</b>	<ul style="list-style-type: none"> <li>• <b>Active Over-Voltage Protection:</b> The secondary control circuit takes the over if output voltage exceeds <math>110\% \pm 5\%</math> of nominal voltage. Beyond this, output voltage clamps.</li> <li>• <b>Passive Over-Voltage Protection:</b> Zener diode installed on output terminals, selected at <math>120\% \pm 10\%</math> of nominal voltage.</li> </ul>
	<b>Efficiency</b>	<p>For 18 to 48Vdc input with 28V/36A output: 88-89% typical</p> <p>For 12-100Vdc input with 28V/36A output: 85% typical</p>
	<b>Current Limit &amp; Overload</b>	<p>Constant current limit operation. Can be programmed by factory. Other options available.</p>
	<b>Over Temp. Protection</b>	<p>Output shuts down if base plate temperature exceeds <math>+105^{\circ}\text{C} \pm 5^{\circ}\text{C}</math>. Automatic recovery when baseplate temperature returns to below <math>+95^{\circ}\text{C} \pm 5^{\circ}\text{C}</math>.</p>

## M7531 Series– DC/DC Power Supply

### Specifications (Cont.):

<b>Control &amp; Indication</b>	<b>INHIBIT Signal</b>	<p><u>Description:</u> Inhibits output.  <u>Use:</u> Apply short circuit or TTL "LOW" to turn off the power supply.            Leave open or apply TTL "HIGH" to turn on the power supply.  <u>Referenced to:</u> SIGNAL RTN</p>
	<b>SIGNAL RTN</b>	<p><u>Description:</u> Signals return reference.  <u>Referenced to:</u> Connected by a 100 Ω resistor to INPUT RTN</p>
	<b>POR Optional</b>	<p><u>Description:</u> The <b>POR</b> signal disables the input under voltage lockout, input over voltage lockout, over temperature protection and peak load duration limiter.  <b>Please consult factory for details.</b></p>
<b>Environment Designed to meet MIL-STD-810F</b>	<b>Temperature</b>	<p>Methods 501.4 &amp; 502.4            Operating: –55 °C to +85 °C (at baseplate)</p>
<b>EMI</b>	<b>MIL-STD-461F</b>	<p>Designed to meets* MIL-STD-461F CE101, CE102, CS101, CS114, CS115, CS116, RE101, RE102, RS101, RS103            *EMI Compliance achieved with 50μH LISN, shielded harness and static resistive load.</p>
<b>Reliability</b>	150,000 hours, calculated per MIL-HDBK-217F Notice 2 at +85 °C baseplate, Ground Fix conditions.	
<b>Cooling Requirements</b>	The M7531 is a baseplate cooled unit. The base of the M7531 should be thermally attached to a suitable heatsink that maintains it below +85 °C.	
<b>Form factor</b>	4.76" wide, 1.29" high and 6.40" deep. For detailed dimensions and tolerances see Drawing: TBD.	
<b>Weight</b>	Approx. 1100 g TBD.	
<b>Connectors</b>	<p><b>Input connector - J1</b>  <b>Connector type:</b> M24308/24-40F or eq.</p> <p><b>Output connector – J2</b>  <b>Connector type:</b> M24308/23-39F or eq.</p>	

**M7531 Series— DC/DC Power Supply**

**TYPICAL CONNECTION DIAGRAM**

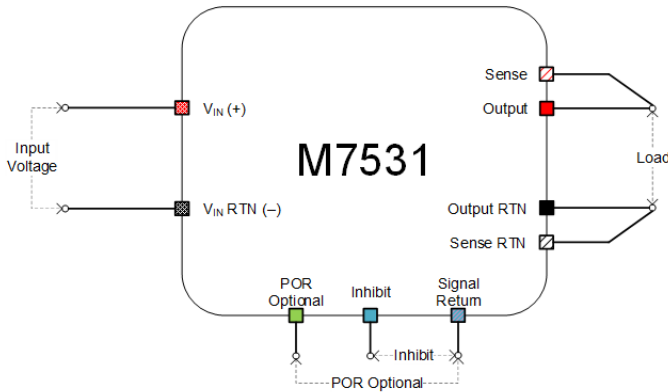

**OPTIONAL PARALLEL CONNECTION DIAGRAM**

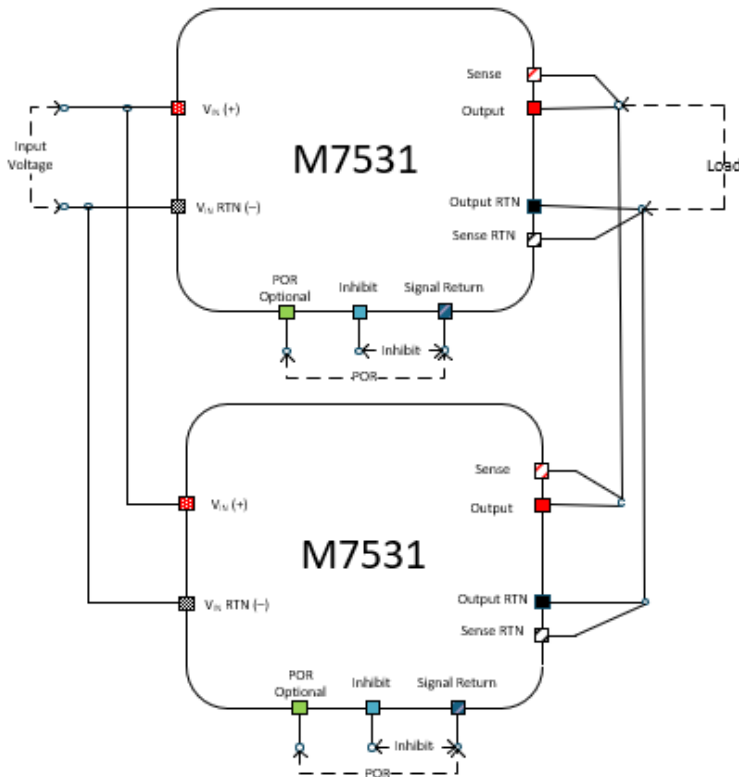

**Note:** Parallel operation via output voltage droop. Voltage regulation is  $\pm 2\%$ .

## M7531 Series– DC/DC Power Supply

### PIN ASSIGNMENT:

#### Input connector - J1

Connector type: M24308/24-40F or eq.

Pin No.	Function	P	Pin No.	Function	P	Pin No.	Function	P
1	INPUT	+	14	INPUT RTN	-	27	INPUT	+
2	INPUT	+	15	INPUT RTN	-	28	INPUT RTN	-
3	INPUT	+	16	INPUT RTN	-	29	INPUT RTN	-
4	INPUT	+	17	N.C.		30	INPUT RTN	-
5	INPUT	+	18	INHIBIT	+	31	INPUT RTN	-
6	INPUT	+	19	N.C	+	32	INPUT RTN	-
7	INPUT	+	20	INPUT	+	33	INPUT RTN	-
8	INPUT	+	21	INPUT	+	34	INPUT RTN	-
9	INPUT RTN	-	22	INPUT	+	35	INPUT RTN	-
10	INPUT RTN	-	23	INPUT	+	36	CHASSIS	
11	INPUT RTN	-	24	INPUT	+	37	SIGNAL RTN	-
12	INPUT RTN	-	25	INPUT	+			
13	INPUT RTN	-	26	INPUT	+			

#### Output connector – J2

Connector type: M24308/23-39F or eq.

Pin No.	Function	P	Pin No.	Function	P	Pin No.	Function	P
1	SENSE	+	10	OUTPUT RTN	-	19	N/A	
2	OUTPUT	+	11	OUTPUT RTN	-	20	N/A	
3	OUTPUT	+	12	OUTPUT RTN	-	21	OUTPUT RTN	-
4	OUTPUT	+	13	SENSE RTN	-	22	OUTPUT RTN	-
5	OUTPUT	+	14	OUTPUT	+	23	OUTPUT RTN	-
6	OUTPUT	+	15	OUTPUT	+	24	OUTPUT RTN	-
7	DGND		16	OUTPUT	+	25	OUTPUT RTN	-
8	OUTPUT RTN	-	17	OUTPUT	+			
9	OUTPUT RTN	-	18	OUTPUT	+			

**Note:** All pins with identical function/designation should be connected together for optimal performance.

**M7531 Series– DC/DC Power Supply**

**OUTLINE DRAWING:**

For detailed dimensions and tolerances see Drawing: M7531001

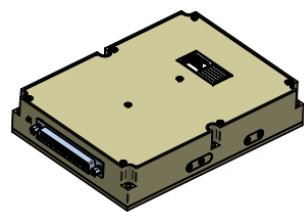
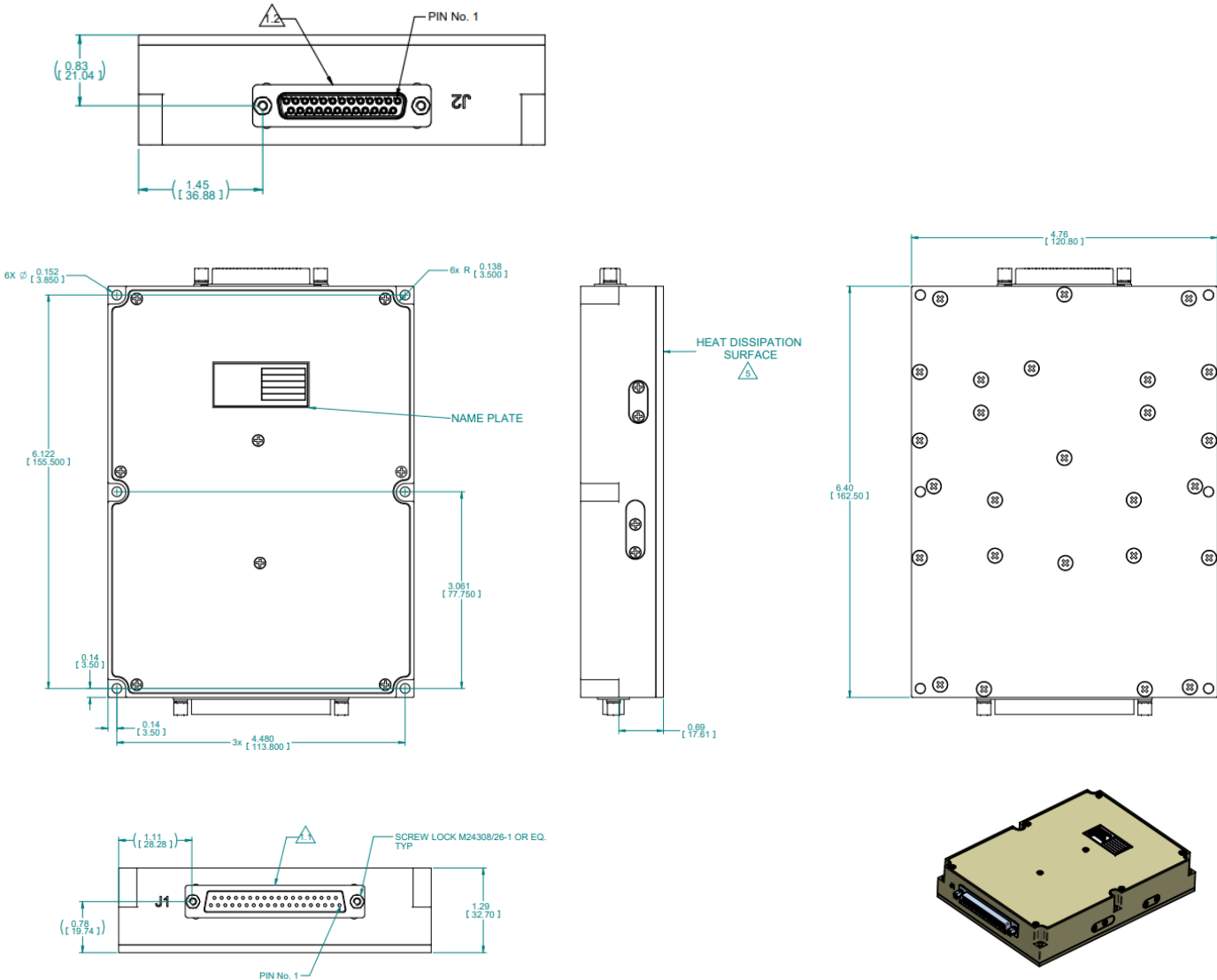

**NOTES :**

1. CONNECTORS:
  - 1.1 - INPUT PLUG D-TYPE CONN. 37P, P/N: M24308/24-40F OR EQ.
  - 1.2 - OUTPUT SOCKET D-TYPE CONN. 25P, P/N: M24308/23-39F OR EQ.
2. WORKMANSHIP SHALL BE MIL-STD-454, REQT. 9
3. MTL. AL 6061-T651& AL 5052-H32
4. CHROMATE CONVERSION COATING PER MIL-DTL-5541F, TYPE 1 CLASS 1A
5. HEAT DISSIPATION SURFACE: 30.43 in<sup>2</sup> [19,630 mm<sup>2</sup>]
6. ENGRAVING:
  - CHARACTERS HEIGHT: 0.157in [4mm] DEPTH: 0.157in [4mm].
  - FILL ENGRAVING WITH BLACK LUSTERLESS
  - EPOXY PAINT COLOR PER FED-STD 595 NO : 37038.

DIMENSIONS ARE IN INCH [MM]  
DO NOT SCALE DRAWING

GENERAL TOLERANCES  
X.XX ± .02 [0.50]  
X.XXX ± .006 [0.15]  
ANGLES ± 1°

Note: Specifications are subject to change without prior notice by the manufacturer.