

M7529 SERIES

SINGLE-OUTPUT, 1000W DC TO DC BASEPLATE COOLED POWER SUPPLY, SEALED UNIT

The M7529 is a series of mechanically robust, base-plate cooled, high performance, power supplies, designed for Airborne (MIL-STD-704), Ground Mobile (MIL-STD-1275) and other Hi-Reliability applications. The M7529 converts MIL-STD-704F and MIL-STD-1275E 28V power, to a well regulated, filtered and protected DC Output.



M7529 Series– DC/DC Power Supply

Standard Models List (for other voltages – consult factory)

Part Number	Output		Power	Special features	Type	
	Voltage	Current			A	B
M7529-101	12 V _{DC}	50 A	600W			V
M7529-102	15 V _{DC}	50 A	750W			V
M7529-103	24 V _{DC}	42 A	1008W			V
M7529-104	28 V _{DC}	36 A	1008W		V	
M7529-105	48 V _{DC}	21A	1008W		V	
M7529-106	28 V _{DC}	36A	1008W	Parallel operation via output voltage droop. Voltage regulation is ±2%.	V	
M7529-801	12 V _{DC}	50 A	600W			V
M7529-802	15 V _{DC}	50 A	750W			V
M7529-803	24 V _{DC}	42 A	1008W			V
M7529-804	28 V _{DC}	36 A	1008W		V	
M7529-805	48 V _{DC}	21A	1008W		V	
M7529-806	28 V _{DC}	36A	1008W	Parallel operation via output voltage droop. Voltage regulation is ±2%.	V	

Notes For M7529-8XX:

- This Product is REACH Compliant.
 - The aluminum parts comprising this converter are chromate conversion coated per MIL-DTL-5541F, Type II CLASS 1A or eq.
-
- Additional standard configurations available. **Contact factory for more details.**
 - All of our products can be configured to comply with EU REACH regulations. **Contact factory for more details.**
 - Rides through transients IAW MIL-STD-1275E and MIL-STD-704F.

M7529 Series– DC/DC Power Supply

THE MAIN FEATURES OF THE M7529 ARE:

- DC/DC Single outputs power supply up to 1000W
- Standard Input version IAW MIL-STD-704F
- Standard Input version IAW MIL-STD-1275E
- Rides through transients IAW MIL-STD-1275E and MIL-STD-704F
- High efficiency – up to 86% (depending on output voltage).
- Full galvanic isolation between Input, Chassis and Outputs
- Fixed switching freq. (250 kHz)
- EMI filters included
- Indefinite short circuit protection with auto-recovery
- Over-voltage protection
- Over temperature shutdown with auto-recovery
- High density
- Sealed enclosure
- Conduction cooled via the baseplate

M7529 Series– DC/DC Power Supply

SPECIFICATIONS:

DC Input	<i>Voltage Range</i>	28VDC input IAW MIL-STD-704F and MIL-STD-1275E
	<i>Transients</i>	Rides through transients IAW MIL-STD-1275E and MIL-STD-704F: 12V, 1sec 16V, 30sec 18V Continues 50V Continues 100V, 50msec
	<i>Isolation</i>	Input to Output: 200 VDC Input to Case: 200 VDC
	<i>Input Reverse Polarity</i>	Protection for unlimited time
	<i>Under-Voltage Lock-Out</i>	Unit shuts down when input voltage falls below 10.5VDC ±1VDC Please consult factory for more details.
	<i>Over-Voltage Lock-Out</i>	Unit shuts down when input voltage rises above 104V _{DC} ±2V _{DC} Please consult factory for more details.
DC Output	<i>Voltage Regulation</i>	Better than or equal to ±1% (low to high line voltage, no load to full load, –55 °C to +80 °C at baseplate).
	<i>Remote Sense for type A only</i>	<u>Description</u> : Used to achieve accurate voltage regulation at load terminals, to compensate for voltage drop across the leads connecting the converter to the load, 0.25 V ± 0.1 V <u>Use</u> : Connect SENSE line directly to the load's positive terminal, and SENSE RTN directly to the load's negative terminal. If not used, connect SENSE to OUTPUT and SENSE RTN to OUTPUT RTN. Do not leave open!
	<i>Ripple</i>	Less than 50mV _{p-p} , typical (max. 1%) without external capacitance. When connected to system capacitance ripple drops significantly.
	<i>Isolation</i>	Output to Case: 100 VDC

M7529 Series– DC/DC Power Supply

	<i>Overvoltage Protection</i>	<ul style="list-style-type: none"> Active Over-Voltage Protection: The secondary control circuit takes the over if output voltage exceeds $110\% \pm 5\%$ of nominal voltage. Beyond this, output voltage clamps. Passive Over-Voltage Protection: Zener diode installed on output terminals, selected at $120\% \pm 10\%$ of nominal voltage.
	<i>Efficiency</i>	<p>Typical 86% (28V_{DC} output, nominal input voltage, full load, room temperature)</p> <p>For extended input range - Please consult factory for more details.</p>
	<i>Current Limit & Overload</i>	<p>Output voltage turns off and on periodically with low duty cycle (hiccup) to protect system conductors and converter from short circuit</p>
	<i>Over Temp. Protection</i>	<p>Output shuts down if base plate temperature exceeds $+100^{\circ}\text{C} \pm 5^{\circ}\text{C}$. Automatic recovery when baseplate temperature returns to below $+90^{\circ}\text{C} \pm 5^{\circ}\text{C}$.</p>

M7529 Series– DC/DC Power Supply

Specifications (Cont.):

Environment Designed to meet MIL-STD- 810F	Temperature	Methods 501.4 & 502.4 Operating: –55 °C to +80 °C (at baseplate) Storage: –55 °C to +125 °C (ambient)
	Humidity	Method 507.4 Up to 95% RH
	Salt-fog	Method 509.4
	Altitude	Method 500.4 Procedures I – Storage/Air transport: up to 70,000 ft. (non-operational) Procedure II – Operation/Air Carriage: up to 70,000 ft. (operational)
	Mechanical Shock	Method 516.5 Procedure I 30 g / 11 ms terminal peak saw-tooth
	Vibration	Method 514.5 Category 4 - General minimum integrity exposure IAW Figure 514.5C-17 1 hour per axis.
	Fungus	Does not support fungus growth, in accordance with the guidelines of MIL-STD-454, Requirement 4-
IP	IP rating	IP67 ⁽¹⁾
EMI	MIL-STD-461F	Designed to meets ⁽²⁾ MIL-STD-461F CE101, CE102, CS101, CS114, CS115, CS116, RE101, RE102, RS101, RS103
Reliability	150,000 hours, calculated per MIL-HDBK-217F Notice 2 at +80 °C baseplate, Ground Fix conditions.	
Cooling Requirements	The M7529 is a baseplate cooled unit. The base of the M7529 should be thermally attached to a suitable heatsink that maintains it below +80 °C.	
Form factor	270mm length 150mm width and 61mm height	
Weight	3.6kg Typical	

M7529 Series– DC/DC Power Supply

Connectors	<p>Input connector - J1 Connector type: : D38999/24WE6PN OR EQ.</p> <p>Output connector – J2 Connector type: D38999/24WE6SN OR EQ.</p>
Connectors for REACH configurations	<p>Input connector - J1 Connector type: : AMPHENOAL P/N TV07DT17-06P OR EQ.</p> <p>Output connector – J2 Connector type: AMPHENOAL P/N TV07DT17-06S OR EQ.</p>

Note:

- (1) When the connectors and mating connectors are connected.
- (2) Compliance achieved with 5μH LISN, shielded harness and static resistive load.

M7529 Series– DC/DC Power Supply

CE 102
Test 28V Vin

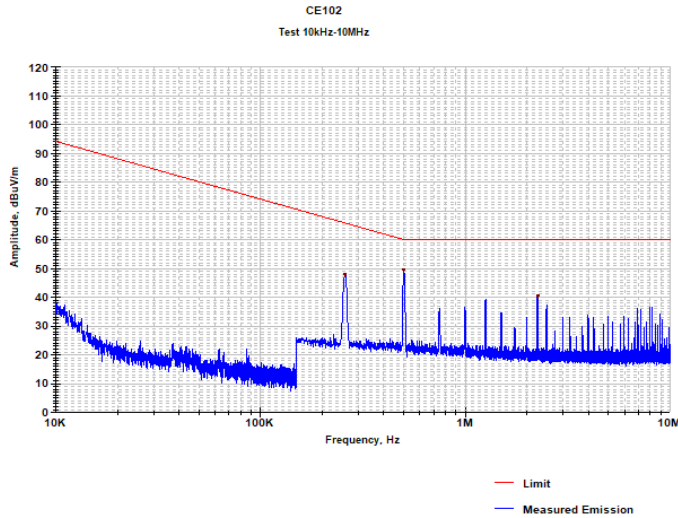

Frequency (MHz)	Measured Emission (dBuV/m)	Limit (dBuV/m)	Delta (dB)
0.258	48.0	65.7	-17.7
0.501	49.4	60.0	-10.6
2.250	40.5	60.0	-19.5

Test 28V RTN

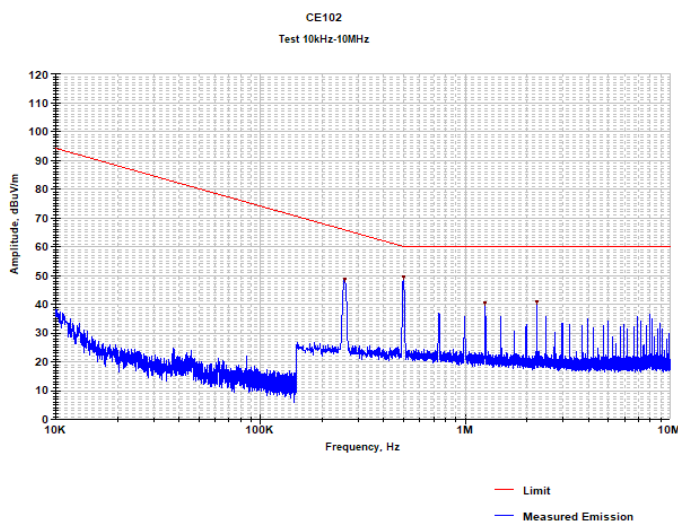

M7529 Series– DC/DC Power Supply

Frequency (MHz)	Measured Emission (dBuV/m)	Limit (dBuV/m)	Delta (dB)
0.257	48.6	65.8	-17.2
0.499	49.4	60.0	-10.7
1.249	40.4	60.0	-19.6
2.240	40.8	60.0	-19.2

Plot 11.9: RE102 test results within 2– 30 MHz, vertical polarization

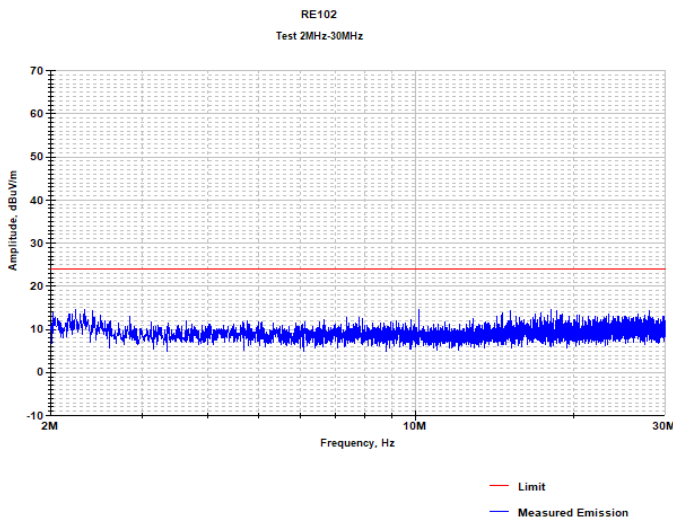

Plot 11.14: RE102 test results within 30 – 200 MHz, vertical polarization

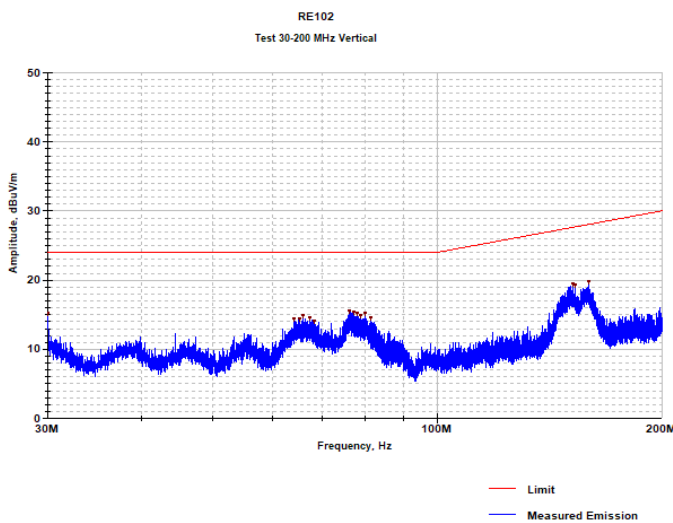

M7529 Series– DC/DC Power Supply

Frequency (MHz)	Measured Emission (dBuV/m)	Limit (dBuV/m)	Delta (dB)
30.017	15.23	24.00	-8.77
64.204	14.42	24.00	-9.58
65.224	14.31	24.00	-9.69
65.955	14.84	24.00	-9.16
67.451	14.48	24.00	-9.52
68.403	14.11	24.00	-9.89
76.121	15.50	24.00	-8.50
77.090	15.27	24.00	-8.73
78.093	15.14	24.00	-8.86
78.875	14.91	24.00	-9.09
79.861	15.13	24.00	-8.87
81.357	14.55	24.00	-9.45
151.805	19.51	27.62	-8.11
153.046	19.32	27.69	-8.37
159.234	19.82	28.03	-8.21

Plot 11.15: RE102 test results within 30 – 200 MHz, horizontal polarization

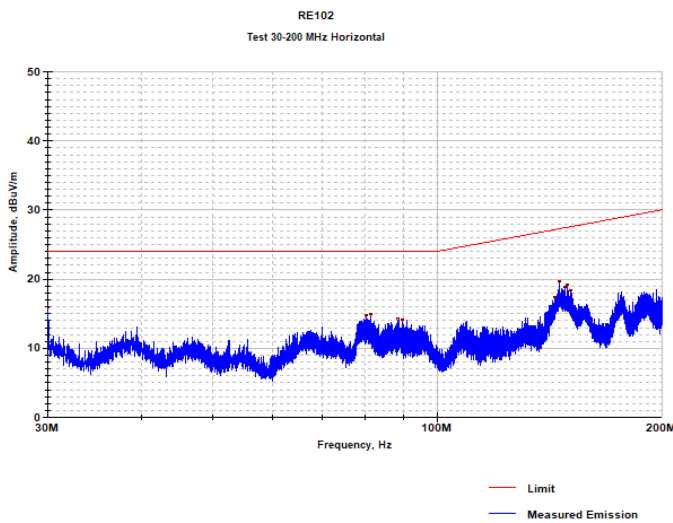

M7529 Series– DC/DC Power Supply

Frequency (MHz)	Measured Emission (dBuV/m)	Limit (dBuV/m)	Delta (dB)
30.000	15.8	24.0	-8.2
80.167	14.6	24.0	-9.4
81.408	14.8	24.0	-9.2
88.599	14.2	24.0	-9.8
89.619	14.0	24.0	-10.0
143.475	17.4	27.1	-9.8
145.498	19.6	27.2	-7.6
148.235	18.8	27.4	-8.6
149.204	19.2	27.5	-8.3
150.734	18.4	27.6	-9.2

Plot 11.19: RE102 test results within 200 – 1000 MHz, vertical polarization

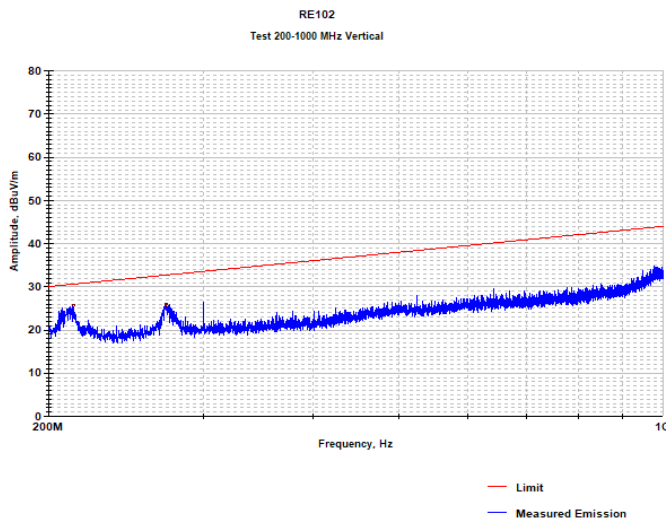

Frequency (MHz)	Measured Emission (dBuV/m)	Limit (dBuV/m)	Delta (dB)
213.760	25.48	30.58	-5.10
272.000	25.86	32.67	-6.81

M7529 Series– DC/DC Power Supply

Plot 11.21: RE102 test results within 200 – 1000 MHz, horizontal polarization

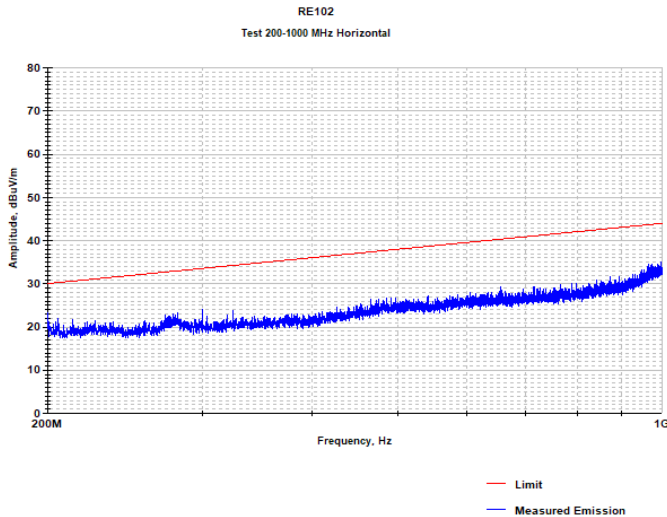

Plot 11.25: RE102 test results within 1000 – 18000 MHz, vertical polarization

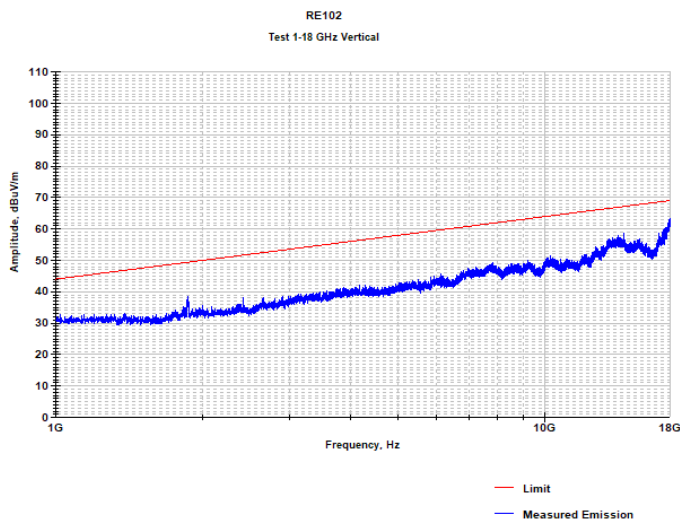

M7529 Series– DC/DC Power Supply

Plot 11.25: RE102 test results within 1000 – 18000 MHz, horizontal polarization

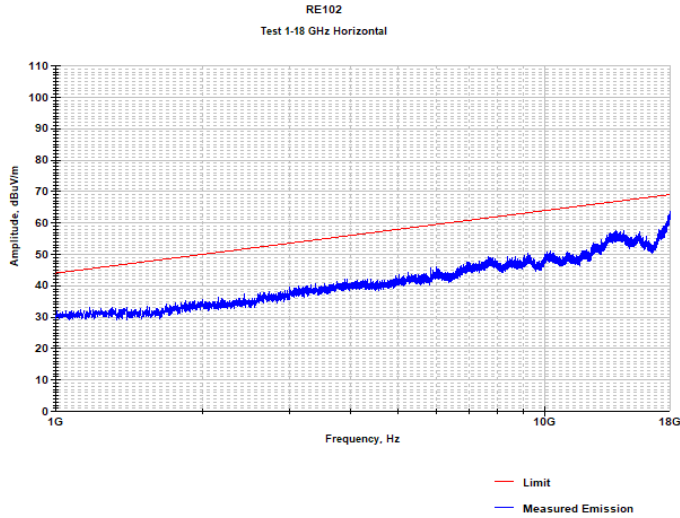

M7529 Series– DC/DC Power Supply

TYPICAL CONNECTION DIAGRAM TYPE A

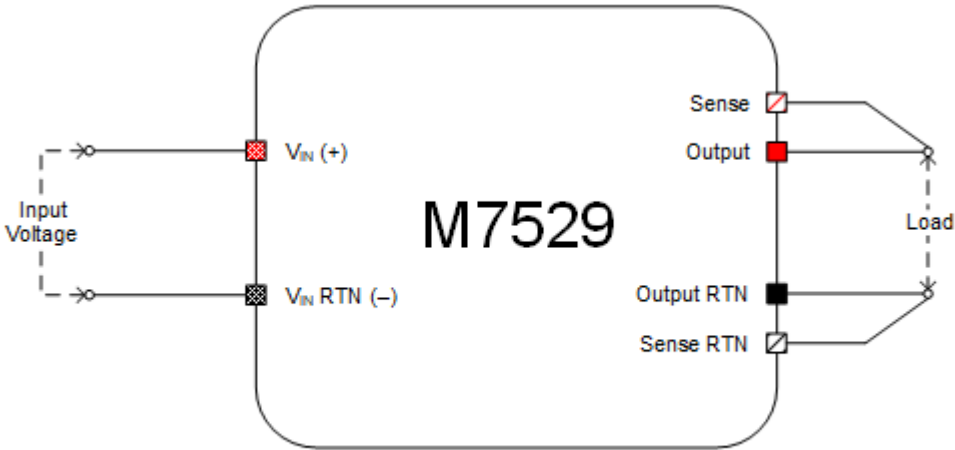

M7529 Series– DC/DC Power Supply

PARALLEL CONNECTION DIAGRAM TYPE A

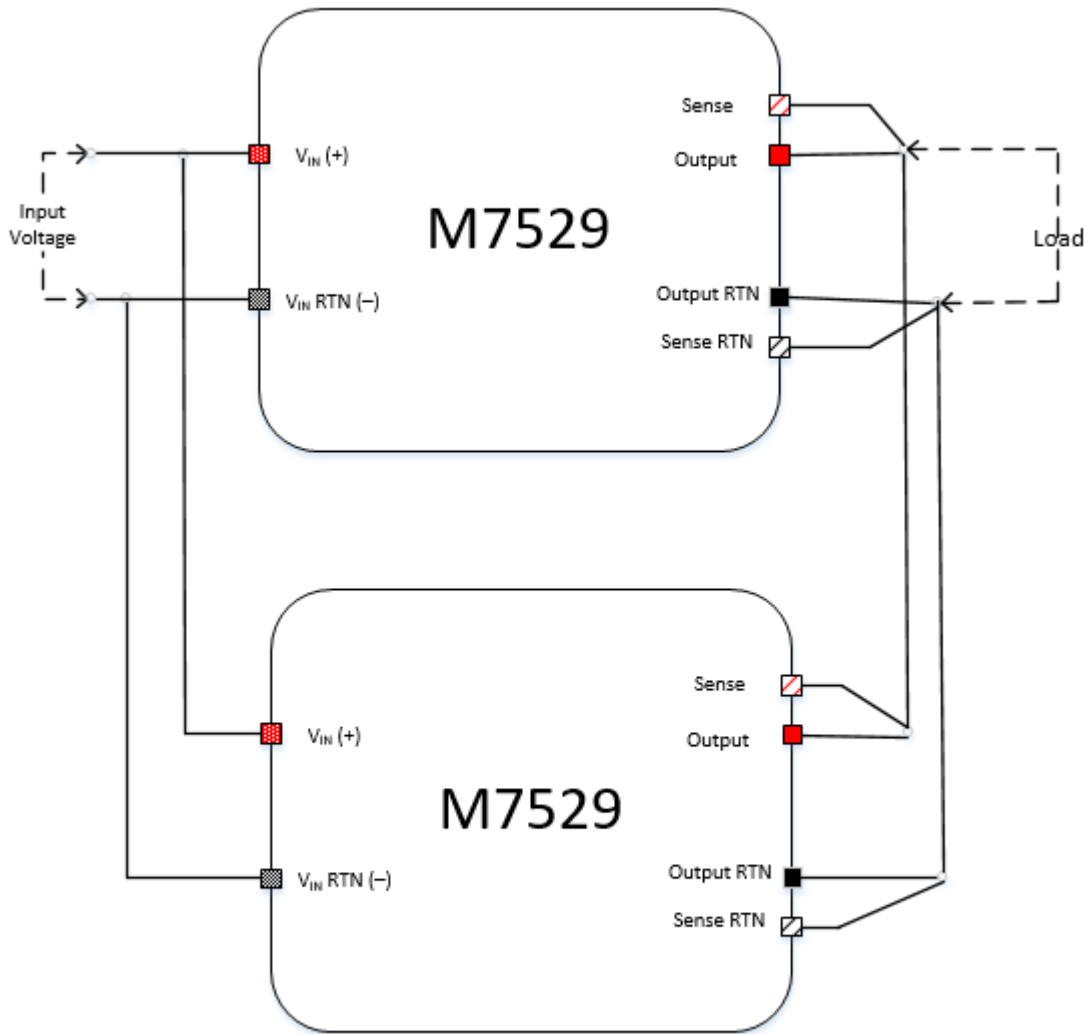

Note: Parallel operation via output voltage droop. Voltage regulation is $\pm 2\%$.

M7529 Series– DC/DC Power Supply

TYPICAL CONNECTION DIAGRAM TYPE B

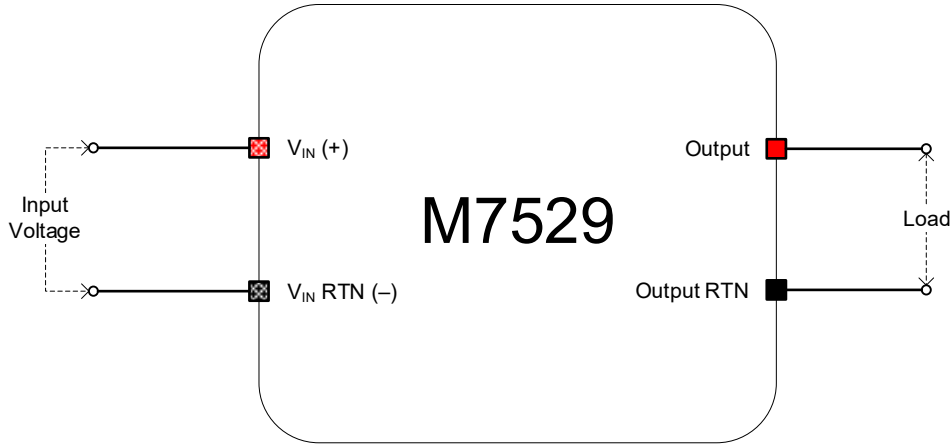

PARALLEL CONNECTION DIAGRAM TYPE B

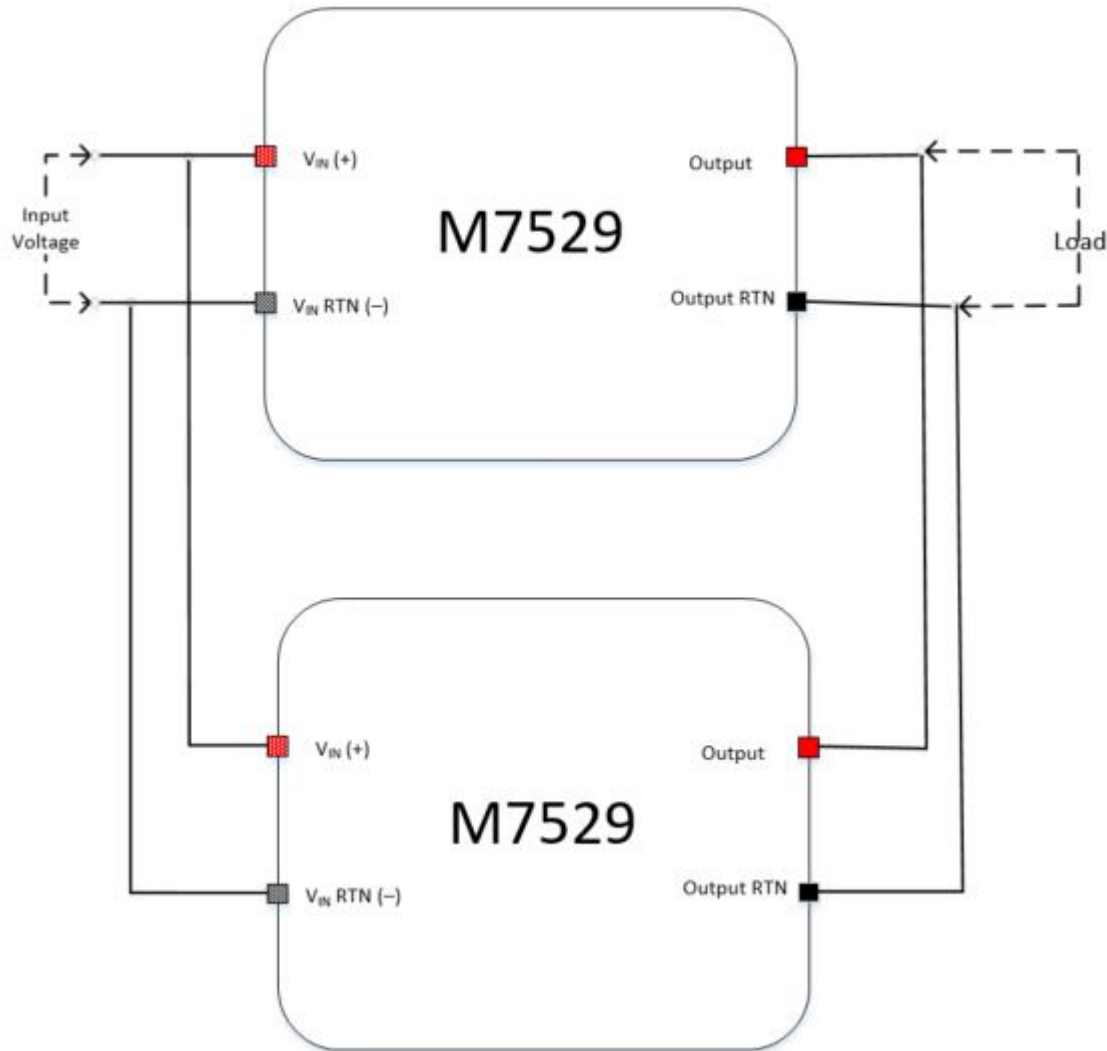

M7529 Series– DC/DC Power Supply

PIN ASSIGNMENT:

Input connector - J1

Connector type: D38999/24WE6PN OR EQ

Pin No.	Function	P
A	VIN	+
B	VIN	+
C	VIN	+
D	VIN RTN	-
E	VIN RTN	-
F	VIN RTN	-

OUTPUT CONNECTOR TYPE A:

Output connector – J2

Connector type: D38999/24WE6SN OR EQ.

Pin No.	Function	P
A	SENSE	+
B	OUT	+
C	OUT	+
D	OUT RTN	-
E	OUT RTN	-
F	SENSE RTN	-

OUTPUT CONNECTOR TYPE B:

Output connector – J2

Connector type: D38999/24WE6SN OR EQ.

Pin No.	Function	P
A	OUT	+
B	OUT	+
C	OUT	+
D	OUT RTN	-
E	OUT RTN	-
F	OUT RTN	-

Note: All pins with identical function/designation should be connected together for optimal performance.

M7529 Series– DC/DC Power Supply

OUTLINE DRAWING:

For detailed dimensions and tolerances see Drawing: M7529001

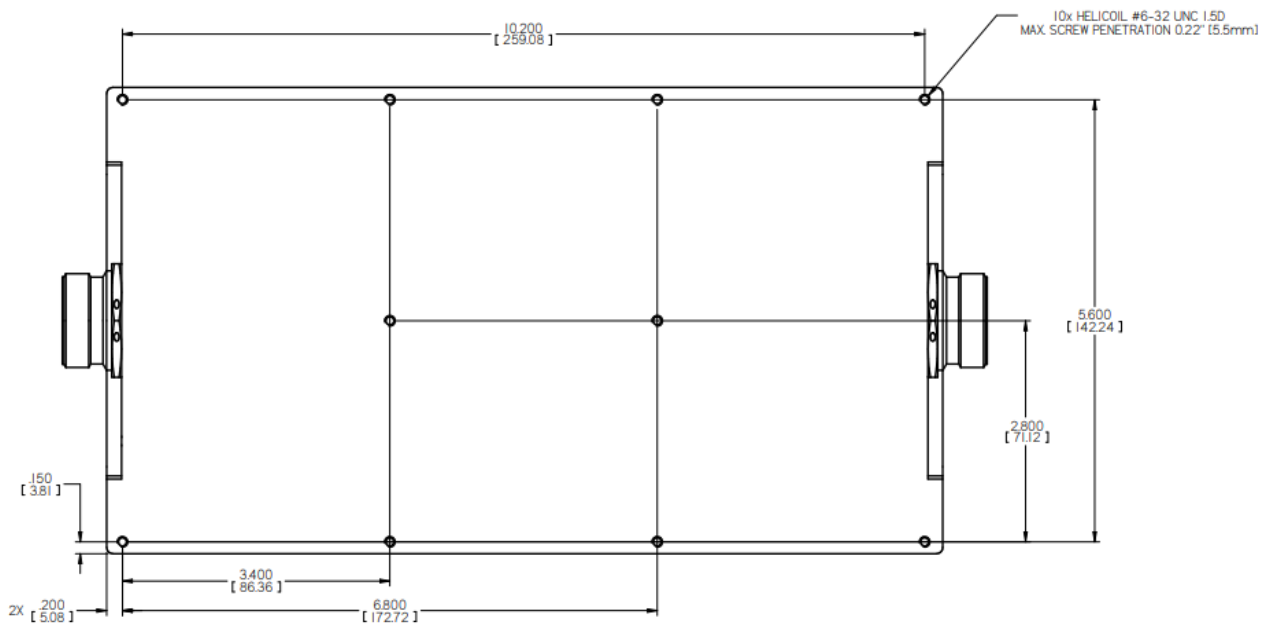
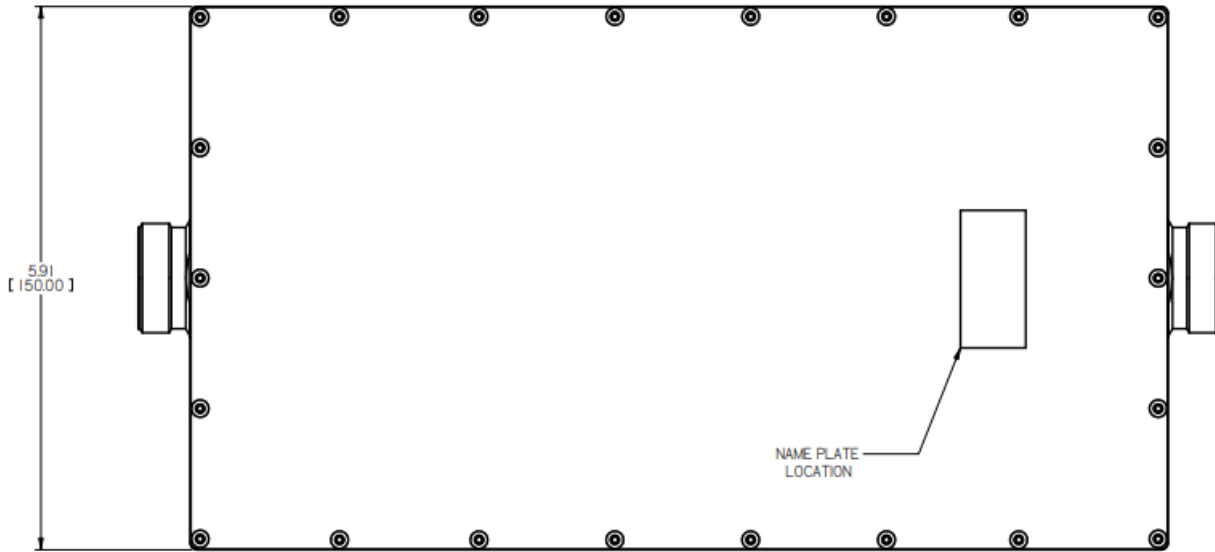

M7529 Series– DC/DC Power Supply

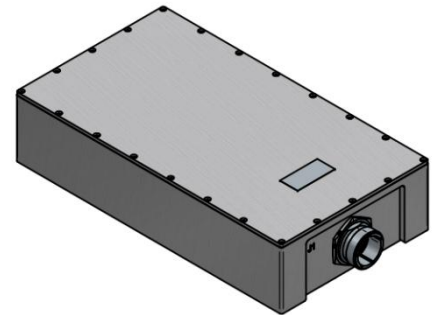
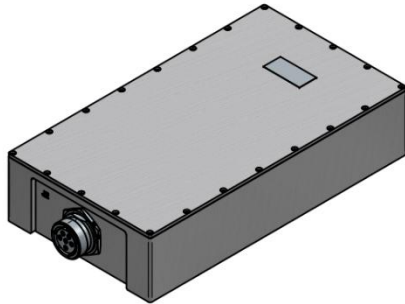
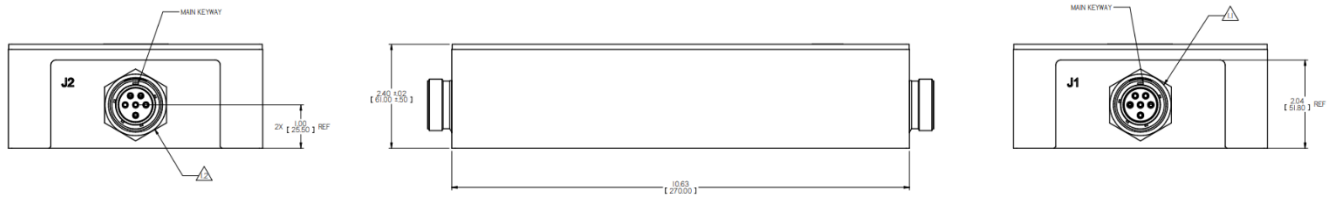

NOTES :

1. CONNECTORS:

- 1.1 - INPUT ROUND CONNECTOR 6P, P/N: D38999/24WE6PN OR EQ.
- 1.2 - OUTPUT ROUND CONNECTOR 6P, P/N: D38999/24WE6SN OR EQ.

2. WORKMANSHIP SHALL BE MIL-STD-454, REQT. 9

3. MTL. AL 6061-T651& AL 5052-H32

4. CHROMATE CONVERSION COATING PER MIL -DTL-5541F, TYPE 1 CLASS 1A

5. HEAT DISSIPATION SURFACE: 55.8 in² [36,000 mm²]

6. ENGRAVING:

6.1 - CHARACTERS HEIGHT: .20" [5mm], DEPTH: .02" [0.5mm].

6.2 - FILL ENGRAVING WITH EPOXY POLYAMIDE PER MIL-PRF-22750, LAST REV.
COLOR BLACK, PER FED-STD-595, COLOR NO. 37038.

M7529 Series– DC/DC Power Supply

OUTLINE DRAWING FOR REACH CONFIGURATIONS:

For detailed dimensions and tolerances see Drawing: M7529-806

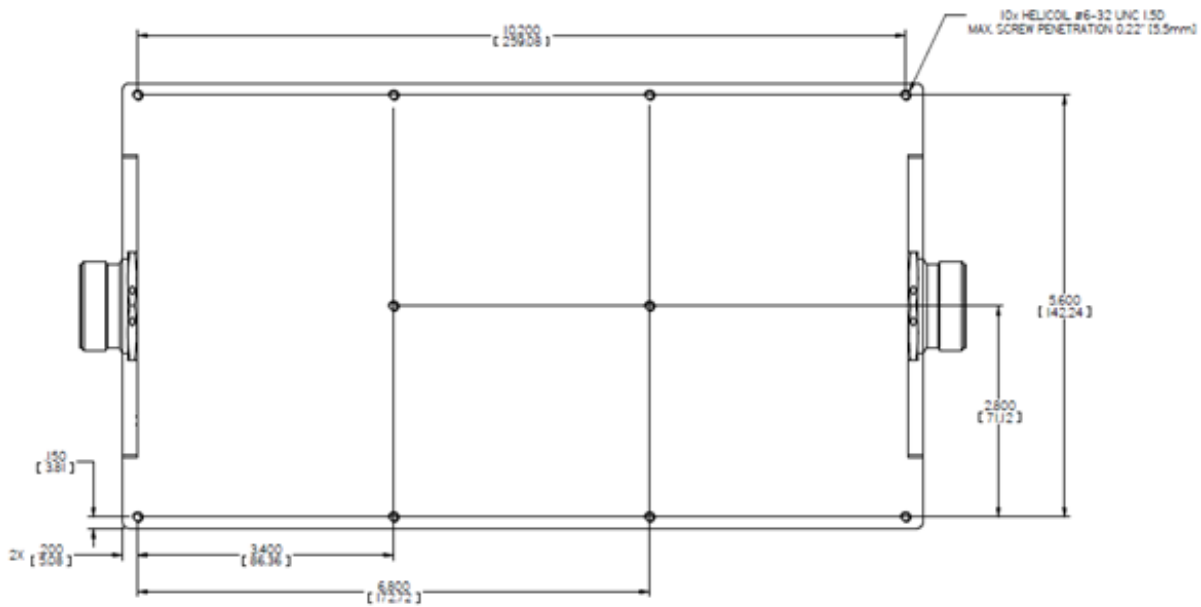
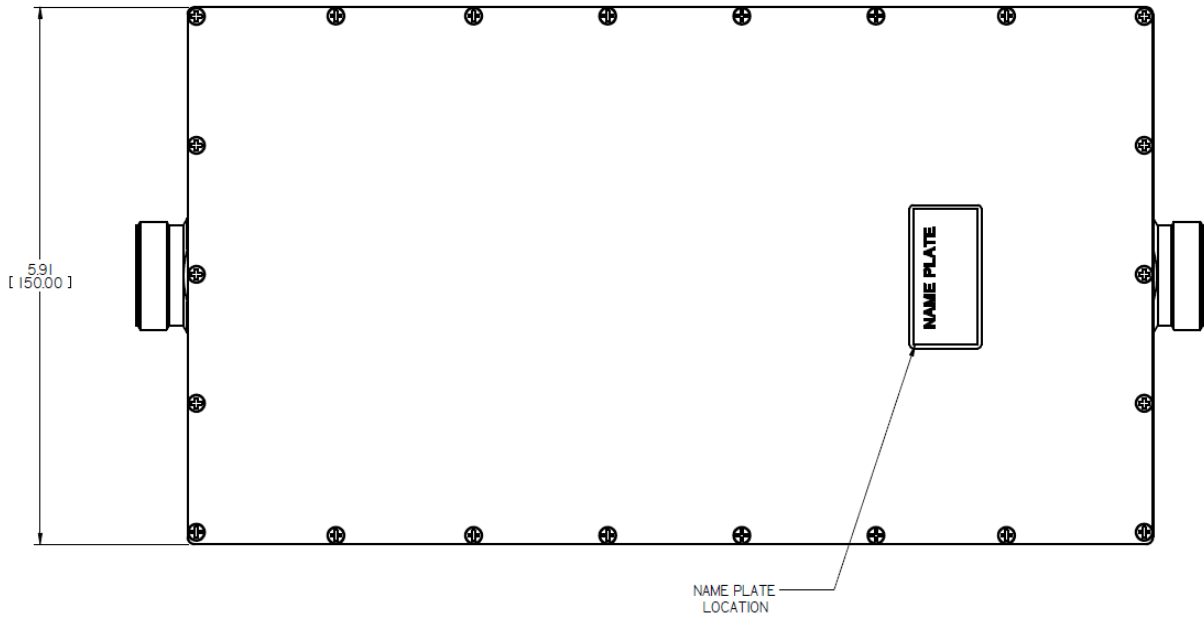

M7529 Series– DC/DC Power Supply

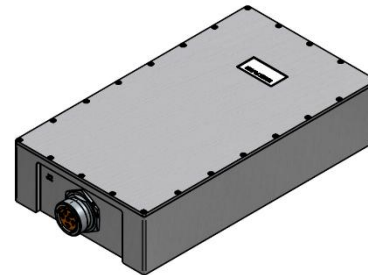
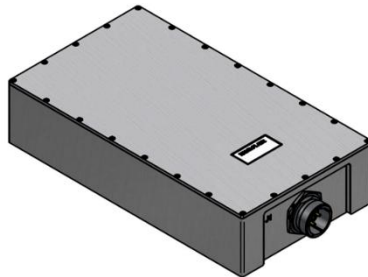

NOTES :

1. CONNECTORS:

- 1.1 - INPUT ROUND CONNECTOR 6P, AMPHENOAL P/N TV07DT17-06P OR EQ.
- 1.2 - OUTPUT ROUND CONNECTOR 6S, AMPHENOAL P/N TV07DT17-06S OR EQ.

2. WORKMANSHIP SHALL BE MIL-STD-454, REQ. 9

3. MTL. AL 6061-T651& AL 5052-H32

4. CHROMATE CONVERSION COATING PER MIL -DTL-5541, LAST REVISION, TYPE II, CLASS 1A, CLEAR.

5. HEAT DISSIPATION SURFACE: 60 in² [39,000 mm²]

6. ENGRAVING:

- 6.1. LINE AND CHARACTER DEPTH: .02" [0.5mm].
- 6.2. CHARACTER HEIGHT: .20" [5mm].
- 6.3. FONT: ARIAL\ ACCORDING TO 3D MODEL.
- 6.4. FILL ENGRAVING WITH BLACK LUSTERLESS EPOXY PAINT PER MIL-PRF-22750, TYPE II, CLASS H, GRADE A, COLOR PER FED-STD 595 N0 : 37038.

Note: Specifications are subject to change without prior notice by the manufacturer.