

M6500 SERIES

DC/DC POWER SUPPLY



PRODUCT HIGHLIGHTS

- MINIATURE
- HIGH DENSITY
- HIGH EFFICIENCY
- SINGLE OUTPUT
- DC/DC POWER SUPPLY
- UP TO 500 W

M6500 SERIES DC/DC POWER SUPPLY

<p>Applications <i>Military (ground-fix, shipboard), Ruggedized, Telecom, Industrial</i></p>											
<p>Special Features</p> <ul style="list-style-type: none"> • Miniature size • High efficiency • Wide input range • Input / Output isolation • Remote sense • External On/Off Inhibit • Zero Voltage Switching Technology • <u>Fixed</u> switching frequency (250 kHz) • External synchronization capability • <u>EMI</u> filters included • Optional parallel connection • Indefinite short circuit protection with auto-recovery • Over-voltage shutdown with auto-recovery • Over temperature shutdown with auto-recovery 											
<p>Electrical Specifications</p> <table border="0" style="width: 100%;"> <tr> <td style="vertical-align: top; width: 33%;"> <p><u>DC Input:</u> 18 to 48V_{DC} per MIL-STD-704E. No damage for: MIL-STD-1275A (100V for 50mSec) MIL-STD-704A (80V for 0.1 Sec)</p> </td> <td style="vertical-align: top; width: 33%;"> <p><u>DC Output:</u> Output range – 3.3V to 28V Output current – max 70A Output power – max 500W</p> </td> <td style="vertical-align: top; width: 33%;"> <p><u>Isolation:</u> 200V between Input and Output 200V between Input and Case 100V between Output and Case</p> </td> </tr> <tr> <td style="vertical-align: top;"> <p><u>Line/Load regulation:</u> Less than 1% (no load to full load, –55°C to +85°C).</p> </td> <td style="vertical-align: top;"> <p><u>Efficiency:</u> Typical 88-90% - (full load, room temperature)</p> </td> <td style="vertical-align: top;"> <p><u>EMC:</u> Designed to meet † MIL-STD-461F CE101, CE102, CS101, CS114, CS115, CS116, RE101, RE102, RS101, RS103</p> </td> </tr> <tr> <td style="vertical-align: top;"> <p><u>Ripple and Noise:</u> Less than 50mV_{p-p}, typical (max. 1%) without external capacitance. When connected to system capacitance ripple drops significantly.</p> </td> <td style="vertical-align: top;"> <p><u>Load Transient Overshoot and undershoot</u> Output resistance at load change of 50%-100% is 30-120mΩ (depending on output voltage). Output back to steady stated within 300-500μSec</p> </td> <td style="vertical-align: top;"> <p><u>Turn on Transient</u> No Voltage over shoot during power on.</p> </td> </tr> </table>			<p><u>DC Input:</u> 18 to 48V_{DC} per MIL-STD-704E. No damage for: MIL-STD-1275A (100V for 50mSec) MIL-STD-704A (80V for 0.1 Sec)</p>	<p><u>DC Output:</u> Output range – 3.3V to 28V Output current – max 70A Output power – max 500W</p>	<p><u>Isolation:</u> 200V between Input and Output 200V between Input and Case 100V between Output and Case</p>	<p><u>Line/Load regulation:</u> Less than 1% (no load to full load, –55°C to +85°C).</p>	<p><u>Efficiency:</u> Typical 88-90% - (full load, room temperature)</p>	<p><u>EMC:</u> Designed to meet † MIL-STD-461F CE101, CE102, CS101, CS114, CS115, CS116, RE101, RE102, RS101, RS103</p>	<p><u>Ripple and Noise:</u> Less than 50mV_{p-p}, typical (max. 1%) without external capacitance. When connected to system capacitance ripple drops significantly.</p>	<p><u>Load Transient Overshoot and undershoot</u> Output resistance at load change of 50%-100% is 30-120mΩ (depending on output voltage). Output back to steady stated within 300-500μSec</p>	<p><u>Turn on Transient</u> No Voltage over shoot during power on.</p>
<p><u>DC Input:</u> 18 to 48V_{DC} per MIL-STD-704E. No damage for: MIL-STD-1275A (100V for 50mSec) MIL-STD-704A (80V for 0.1 Sec)</p>	<p><u>DC Output:</u> Output range – 3.3V to 28V Output current – max 70A Output power – max 500W</p>	<p><u>Isolation:</u> 200V between Input and Output 200V between Input and Case 100V between Output and Case</p>									
<p><u>Line/Load regulation:</u> Less than 1% (no load to full load, –55°C to +85°C).</p>	<p><u>Efficiency:</u> Typical 88-90% - (full load, room temperature)</p>	<p><u>EMC:</u> Designed to meet † MIL-STD-461F CE101, CE102, CS101, CS114, CS115, CS116, RE101, RE102, RS101, RS103</p>									
<p><u>Ripple and Noise:</u> Less than 50mV_{p-p}, typical (max. 1%) without external capacitance. When connected to system capacitance ripple drops significantly.</p>	<p><u>Load Transient Overshoot and undershoot</u> Output resistance at load change of 50%-100% is 30-120mΩ (depending on output voltage). Output back to steady stated within 300-500μSec</p>	<p><u>Turn on Transient</u> No Voltage over shoot during power on.</p>									

† EMC compliance achieved when tested with 5 μH LISNs, shielded harness and static resistive load.

M6500 SERIES DC/DC POWER SUPPLY

Protections *

Input

- **Inrush Current Limiter**
Peak value of $5 \times I_{IN}$ for less than 50 μ Sec.
- **Under voltage protection** Unit shuts down if input voltage falls below $14 \text{ V} \pm 1 \text{ V}$, and turns back on at $16 \text{ V} \pm 1 \text{ V}$
- **Over voltage protection** Unit shuts down if input voltage rises above $54 \text{ V} \pm 2 \text{ V}$, and turns back on at $50 \text{ V} \pm 2 \text{ V}$. Extended versions available for compliance with various standards.

Output

- **Electronic Over Voltage Protection** Internal control protects unit (no damage) 10% above nominal voltage.
- **Passive transorb on outputs** 20% above nominal voltage.
- **Current limiting** Continuous protection (Hiccup) set at 10-30% above nominal current.

General

- **Over temperature protection** Shutdown at base plate temperature of $+105^{\circ}\text{C} (\pm 5^{\circ}\text{C})$ Automatic recovery at base plate temperature lower than $+95^{\circ}\text{C} (\pm 5^{\circ}\text{C})$

* Thresholds and protections can be modified / removed – please consult factory.

Environmental

Design to Meet MIL-STD-810F

Temperature:

Operating: -55°C to $+85^{\circ}\text{C}$
(base plate)

Storage: -55°C to $+125^{\circ}\text{C}$

Humidity:

Method 507.4 - Up to 95%.

Altitude:

Method 500.4, Procedure I & II, 40,000 ft. and 70,000 ft. Operational

Vibration and Shock:

Vibration - Figure 514.5C-17. General minimum integrity exposure. (1 hour per axis.)

Shock - Saw-tooth, 20g peak, 11mS.

Salt Fog:

Method 509-4

Reliability

150,000 hours, calculated per MIL-STD-217F at $+85^{\circ}\text{C}$ base plate, Ground fixed.

Environmental Stress Screening (ESS)

Including random vibration and thermal cycles is also available. **Please consult factory for details.**

M6500 SERIES DC/DC POWER SUPPLY

Pin Assignment Standard

Pin No.	Function
1	+ SENSE
2	SIGNAL RTN
3	SYNC IN
4	INHIBIT
5	- SENSE
6	N.C
7	SYNC OUT

Pin No.	Function
A1	+ OUT
A2	+ OUT
A3	- OUT
A4	- OUT
A5	- VIN
A6	+ VIN

* All pins with the same name and function should be connected together for best performance.

Pin Assignment for Parallel connection

Pin No.	Function
1	+ SENSE
2	SIGNAL RTN
3	SYNC IN
4	INHIBIT
5	- SENSE
6	CURRENT SHARE
7	SYNC OUT

Pin No.	Function
A1	+ OUT
A2	+ OUT
A3	- OUT
A4	- OUT
A5	- VIN
A6	+ VIN

* All pins with the same name and function should be connected together for best performance.

Functions and Signals

INHIBIT signal

The INHIBIT signal is used to turn the power supply ON and OFF.

TTL “1” or OPEN – will turn on the power supply. (For normal operation leave the signal not connected.)

TTL “0” – will turn off the power supply.

SYNC IN signal

The SYNC IN signal is used to allow the power supply frequency to sync with the system frequency. The system frequency should be 250kHz \pm 10kHz.

When not connected the power supply will work at 250kHz

SYNC OUT signal

The SYNC OUT signal is used to sync the system with the power supply frequency.

SIGNAL RTN

The INPUT SIGNAL RTN is referred to the input.

This is used as grounding for SYNC IN, SYNC OUT and INHIBIT signals.

SENSE

The SENSE is used to achieve accurate load regulations at load terminals (this is done by connecting the pins directly to the load’s terminals).

The use of remote sense has a limit of voltage dropout between converter’s output and load terminals of 2-10% of voltage output.

When not used connect + SENSE to +VOUT and –SENSE to –VOUT

CURRENT SHARE [PARALLEL OPERATION VERSION ONLY]

The **CURRENT SHARE** signal is used to connect the power supply in parallel to other power supplies and have them divide equally the power between one another.

Connect all CURRENT SHARE signals of all paralleled power supplies together.

This signal is referenced to - SENSE.

M6500 SERIES DC/DC POWER SUPPLY

Typical Connection

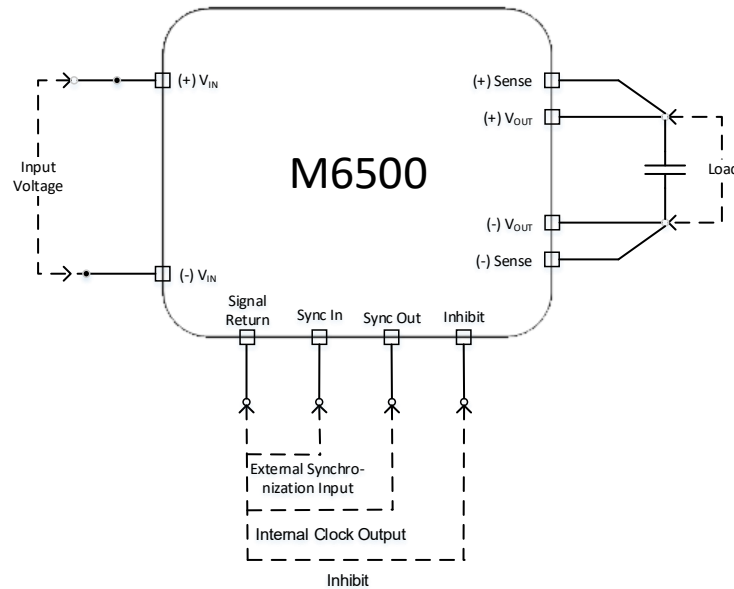

Typical Parallel Connection with Current Share

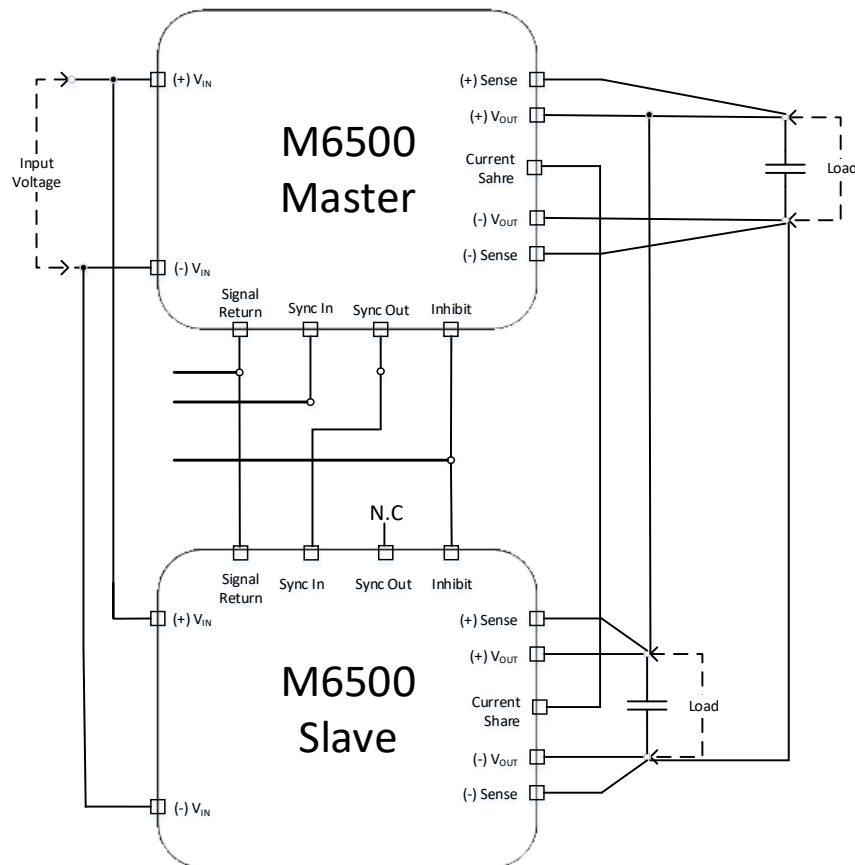

M6500 SERIES DC/DC POWER SUPPLY

Outline Drawing:

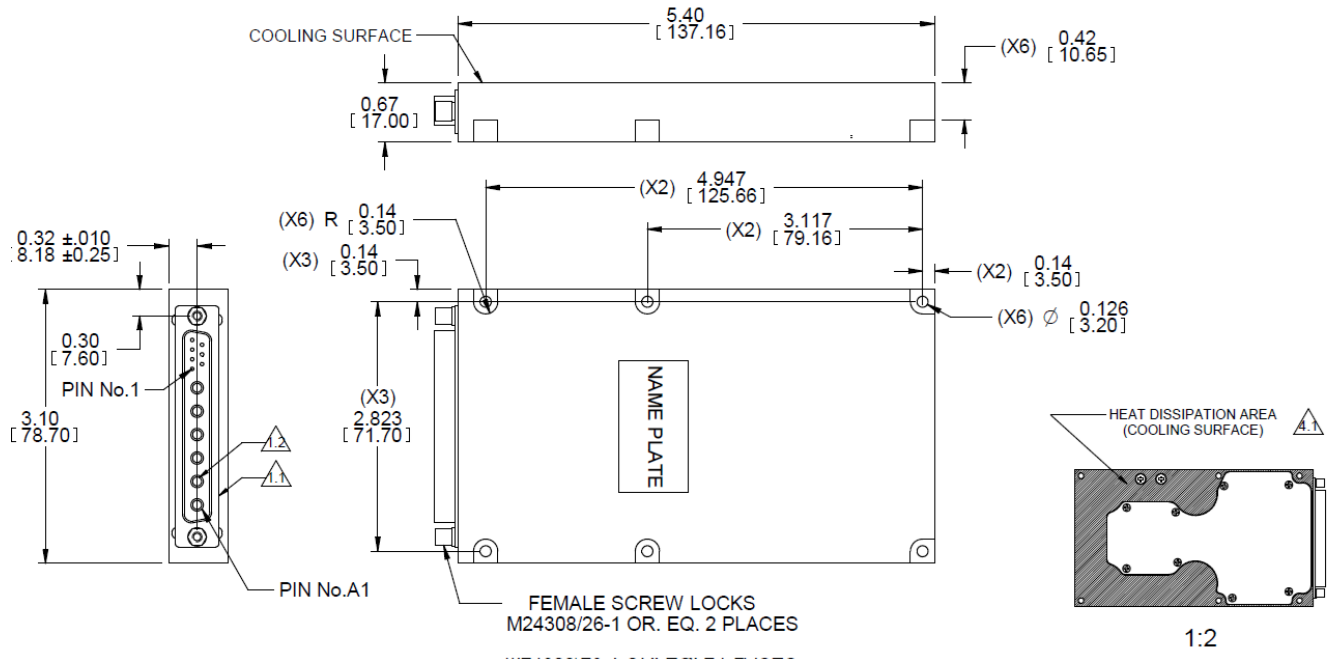

NOTES :

1. CONNECTOR:

- 1.1. POSITRONIC. P/N CBM13W6M5000C, OR EQ.
- 1.2. POWER CONTACTS MS4008D, OR EQ.

2. MTL. AL 6061-T651, AL 5052-H32.

3. FINISH:

- 3.1. CHROMATE CONVERSION COATING PER MIL -DTL-5541, LAST REVISION, TYPE I, CLASS 1A.

4. COOLING:

- 4.1 HEAT DISSIPATION AREA- 6.8 [IN²].

5. WORKMANSHIP SHALL BE MIL-STD-454, REQT. 9.

Notes

- 1. Weight: Approx. 355g (12.52 oz)

Mating connector: solder cup as contact termination type: CBM13W6S2000C
with power pins selected separately:
Solder cup (AVG 8) P/N: FS4008D-15
or
Crimp (AVG 8) P/N: FC4008DS-15

M6500 SERIES DC/DC POWER SUPPLY

Outline Drawing for REACH (-7XX and -8XX) configurations:

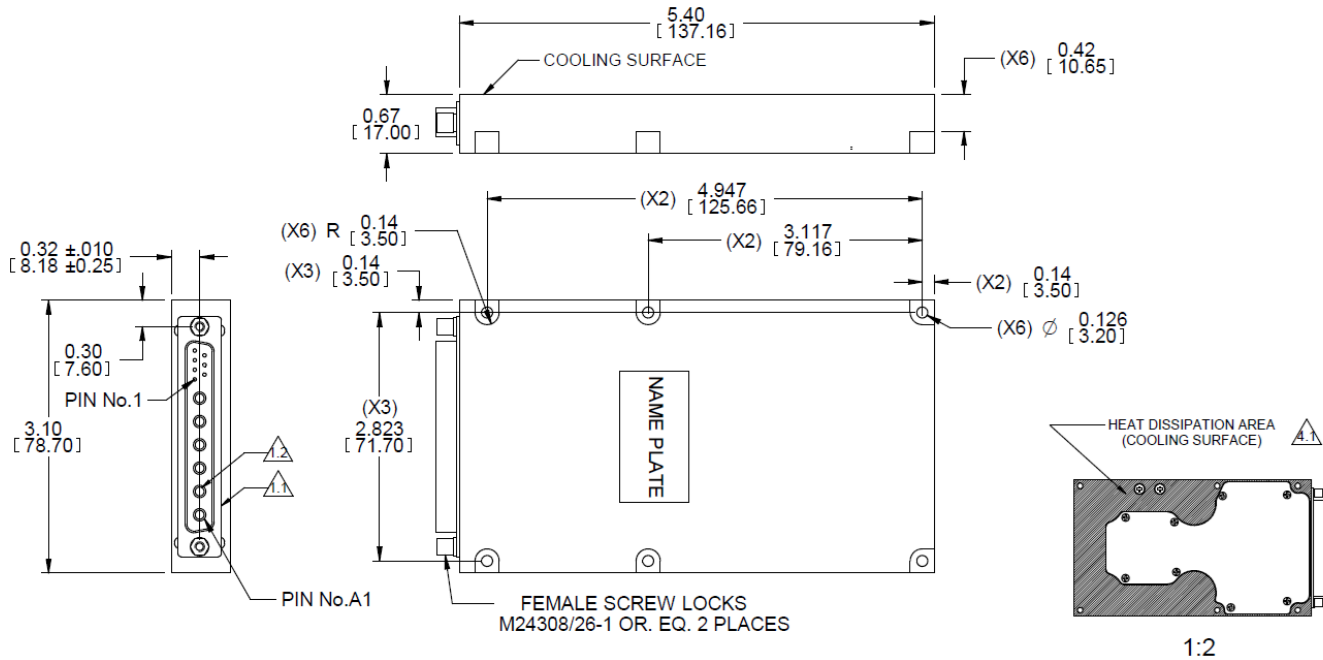

NOTES :

1. CONNECTOR:

- 1.1. POSITRONIC. P/N CBM13W6M50000/AA-1062.0, OR EQ.
- 1.2. POWER CONTACTS MS4008D, OR EQ.

2. MTL. AL 6061-T651, AL 5052-H32.

3. FINISH:

- 3.1. CHROMATE CONVERSION COATING PER MIL -DTL-5541, LAST REVISION, TYPE II, CLASS 1A CLEAR

4. COOLING:

- 4.1 HEAT DISSIPATION AREA- 6.8 [IN²].

5. WORKMANSHIP SHALL BE MIL-STD-454, REQ. 9.

Mating connector: Part number CBM13W6S20000/AA-1062.0

Power pins P/N: FS4008D installed (all pins are solder cup).

M6500 SERIES DC/DC POWER SUPPLY

Standard Configurations Table

Part Number	Input	Output		Power
	Voltage range	Voltage	Current	
M6500-100	18 to 50 V _{DC}	1.8 VDC	60 A	108W
M6500-101	18 to 50 V _{DC}	2.5 VDC	60 A	150W
M6500-102	18 to 50 V _{DC}	3.3 VDC	60 A	198W
M6500-103	18 to 50 V _{DC}	5 VDC	60A	300W
M6500-104	18 to 50 V _{DC}	12 VDC	41 A	492W
M6500-105	18 to 50 V _{DC}	15 VDC	33 A	495W
M6500-106	18 to 50 V _{DC}	24VDC	21 A	495W
M6500-107	18 to 50 V _{DC}	28 VDC	17.5 A	500W
M6500-800*	18 to 50 V _{DC}	1.8 VDC	60 A	108W
M6500-801*	18 to 50 V _{DC}	2.5 VDC	60 A	150W
M6500-802*	18 to 50 V _{DC}	3.3 VDC	60 A	198W
M6500-803*	18 to 50 V _{DC}	5 VDC	60A	300W
M6500-804*	18 to 50 V _{DC}	12 VDC	41 A	492W
M6500-805*	18 to 50 V _{DC}	15 VDC	33 A	495W
M6500-806*	18 to 50 V _{DC}	24VDC	21 A	495W
M6500-807*	18 to 50 V _{DC}	28 VDC	17.5 A	500W

***For -8XX configurations:**

- These configurations are REACH Compliant
- The aluminum parts are chromate conversion coated per MIL-DTL-5541F, Type II CLASS 1A or eq.

Additional standard configurations available. **Contact factory for more details.**

* Specifications are subject to change without prior notice by the manufacturer