

## **M130BA-1 Ruggedized, high performance 1.5KW/2KVA UPS** **In a 19", 4U, 21" deep rack**

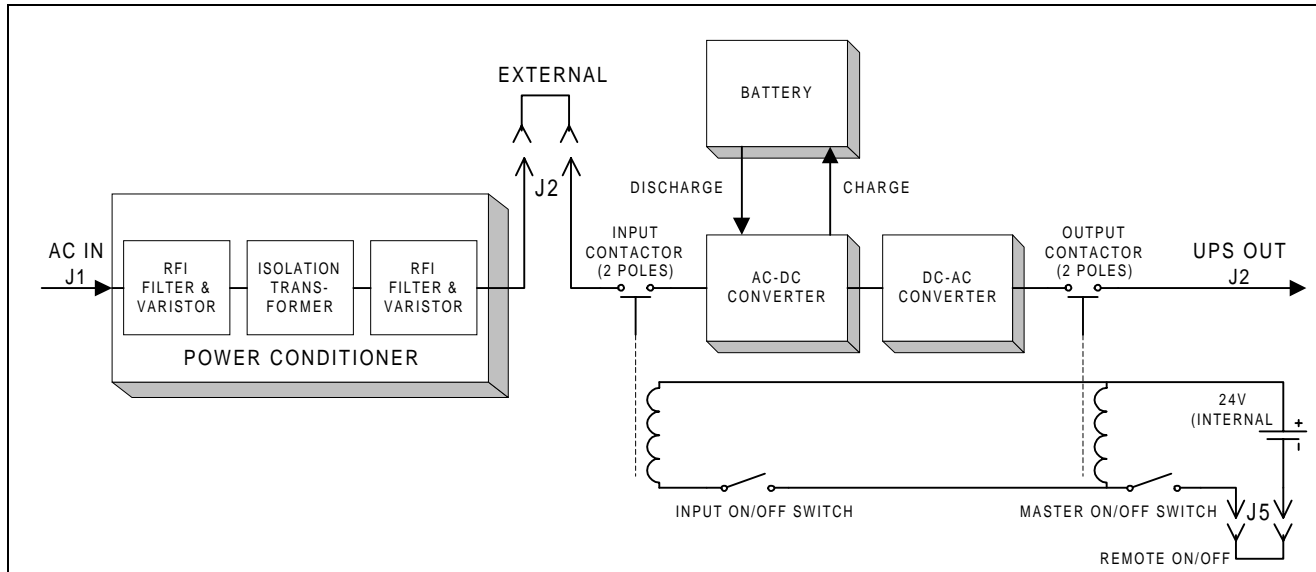

**UPS Block Diagram**

Milpower Source M130BA-1 is a ruggedized, high performance On-Line Uninterruptible Power supply (UPS) intended for military and tough industrial systems. The link between the input isolation transformer (including RFI filters and varistors) and the UPS input is external. Hence, when external bypass is desired, input-output isolation is maintained. The M130BA-1 is designed for use in both ground and shipboard environments. Specifically, in addition to being physically ruggedized, the input stage of this UPS meets all the requirements of MIL-STD -1399 (section 300A). The main features of the M130BA-1 are:

- Ten (10) minutes hold-up time at full rated power.
- Fast charger. Three (3) hours to recharge the battery.
- Pure sine output, digitally synthesized from a crystal oscillator.
- Pure sine input current, with very low harmonic content.
- Better than 98% power factor.
- Very wide input range.
- Insensitivity to high line impedance.
- Very low input-to-chassis capacitance.
- Full galvanic isolation between input and output.
- 1000V / 50 $\mu$ s spike capability.
- MIL-STD-461D compatibility.
- Automatic, periodic battery self-test (using battery resistance method) without interrupting the output.
- MIL-STD-1399 (Section 300A) compatibility.
- Remote ON/OFF.

In order to assure the high reliability of the M130BA-1, J-STD-001B is used as a guideline for workmanship. To enhance reliability and to withstand humid conditions all M130BA-1 printed wiring boards are conformally coated per requirement 17 of MIL-STD-454.

The M130BA-1 utilizes high frequency power MOSFET technology to assure high performance and cool operation. A micro-controller embedded within the M130BA-1 provides control, monitoring and host interface functions.

**Specification**

<b>INPUT</b>	<b><i>Voltage</i></b>	84-165VAC or 180-260VAC (selectable) without switching to battery power. (below this level the battery will be used).
	<b><i>Frequency</i></b>	48-64 Hz
	<b><i>Power Factor</i></b>	> 98%
	<b><i>Spikes</i></b>	200 joules clamping device
	<b><i>Isolation</i></b>	Input is galvanically isolated from output and chassis (> 1 MΩ at 600VDC). Total capacitance between input and chassis is less than 0.02uf per line. Leakage current is less than 2ma. (130dB Input Isolation Transformer.) Both input wires may be "hot" I.A.W. MIL-STD-1399.
	<b><i>Current waveform</i></b>	Sinusoidal with harmonic content of less than 2.5% for harmonics between 2fo to 32fo and less than 100%/N for harmonics between N=32 and 20kHz. (I.A.W. MIL-STD-1399 section 300A.)
	<b><i>Line impedance</i></b>	Up to 5 ohms between 100Hz and 200kHz (I.A.W. MIL-STD-1399 section 300A.)
<b>OUTPUT</b>	<b><i>Voltage</i></b>	115Vac ± 3% , grounded neutral (see Note 1)
	<b><i>Rating</i></b>	2000VA, 1500W
	<b><i>Frequency</i></b>	60Hz ± 0.2% (digitally synthesized from a crystal oscillator)
	<b><i>Waveform</i></b>	Sinusoidal , THD < 2% (linear load), < 4% (non-linear)
<b>BATTERY</b>	<b><i>Type</i></b>	Internal, encapsulated, sealed, maintenance-free, lead-acid.
	<b><i>Capacity</i></b>	Full rated power for at least 10 minutes.
	<b><i>Charger</i></b>	Low ripple, regulated voltage float-charger, with current limiting and temperature compensation. Fully charges the battery within 3 hours (following 10 minutes discharge at full power).
	<b><i>Protection</i></b>	Battery is protected from over-discharge by internal protection circuit (to avoid damage to battery in case of prolonged power outage.)
	<b><i>Monitor</i></b>	Battery charge level and internal impedance are monitored by the UPS micro-controller.
<b>EMC</b>		Meets the requirements of:
	<b><i>Federal</i></b>	FCC Title 47 , part 15, class A.
	<b><i>Military</i></b>	MIL-STD-461D, RE101, RE102, CE101, CE102, CS101 and RS103.
	<b><i>ESD</i></b>	All I/O lines are protected from ESD.

**Specification (continued)**

<b>ENVIRONMENT</b>	<p><i>Temperature</i></p> <p><i>Humidity</i></p> <p><i>Altitude</i></p> <p><i>Orientation</i></p> <p><i>Mechanical shock</i></p> <p><i>Vibration</i></p>	<p>Non operating: -40 to +72°C Note: High temperature for prolonged duration will shorten the battery life. Operating: 0 to +52°C.</p> <p>Up to 95%.</p> <p>Operating: Up to 10,000 feet. Non-operating: (Air transport) 40,000 feet.</p> <p>May be installed at any orientation.</p> <p>When packed, withstands the free fall drop and edgewise drop IAW Methods 5007.1 and 5008.1 of Federal Test Method standard 101C. When operating, withstands the high-impact shipboard shock IAW MIL-S-901D, grade A, class II., Type B.</p> <p>When operating, withstands Type I vibration IAW MIL-STD-167-1. The UPS will endure a sweep of 1.5g sinusoidal vibration from 5 to 50 Hz for a total duration of 2 hours, and random vibration IAW MIL-STD-810D, Cat. 9, Proc. I (test condition I-3.2.11, Fig. 514.3-34)</p>
<b>INDICATIONS &amp; CONTROLS</b>	<p><i>a) Visual Indications (Front panel)</i></p> <p><i>b) Test Mode</i></p> <p><i>c) Audible Alarm</i></p> <p><i>d) Power Switches</i></p> <p><i>e) Remote ON/OFF</i></p>	<p>10-segment tri-color Bar Graph for load level display. 10-segment Bar Graph for battery charge level display. "Output OK", "Output Fail" and "Standby" status lamps. "Input OK" and "Input Fail" status lamps. "On Batt " status lamp. "Batt Passed" and "Batt Failed" lamps for battery self-test. "Low Batt" warning lamp. "Overload Shutdown" status lamp. "Overtemp warning" and "Overtemp Shutdown" lamps.</p> <p>When test mode is invoked by pressing the push-button on the front panel, the UPS performs battery impedance testing without interrupting the output power (even if the battery fails) utilizing a proprietary time-sharing circuit. The test results are displayed on panel indicators. End-to-End testing of the UPS is accomplished by cycling the INPUT ON/OFF switch on the front panel.</p> <p>The UPS will beep when it operates on battery power or during over-temperature condition. The alarm may be silenced by pressing the "Alarm Off" push-button on the front panel.</p> <p>The M130BA-1 has two double-pole contactors, one on the input and one on the output. The input ON/OFF contactor is controlled by the input ON/OFF switch located on the front panel. The Master ON/OFF switch, located on the front panel, shuts down the UPS and opens both input and output contactors when in the OFF position.</p> <p>When the two ON/OFF pins are opened the UPS will turn OFF and the input and output contactors will open. When the two lines are shorted together the front panel switches determine the status. (The UPS is supplied with a mating connector and a jumper between the two ON/OFF pins).</p>

